

Title			
AT91RM9200PQ208电路方框图			
Size	Document Number	Rev	
A4	uCdragon	1.0	
Date:	Sunday, September 04, 2005	Sheet	1 of 13

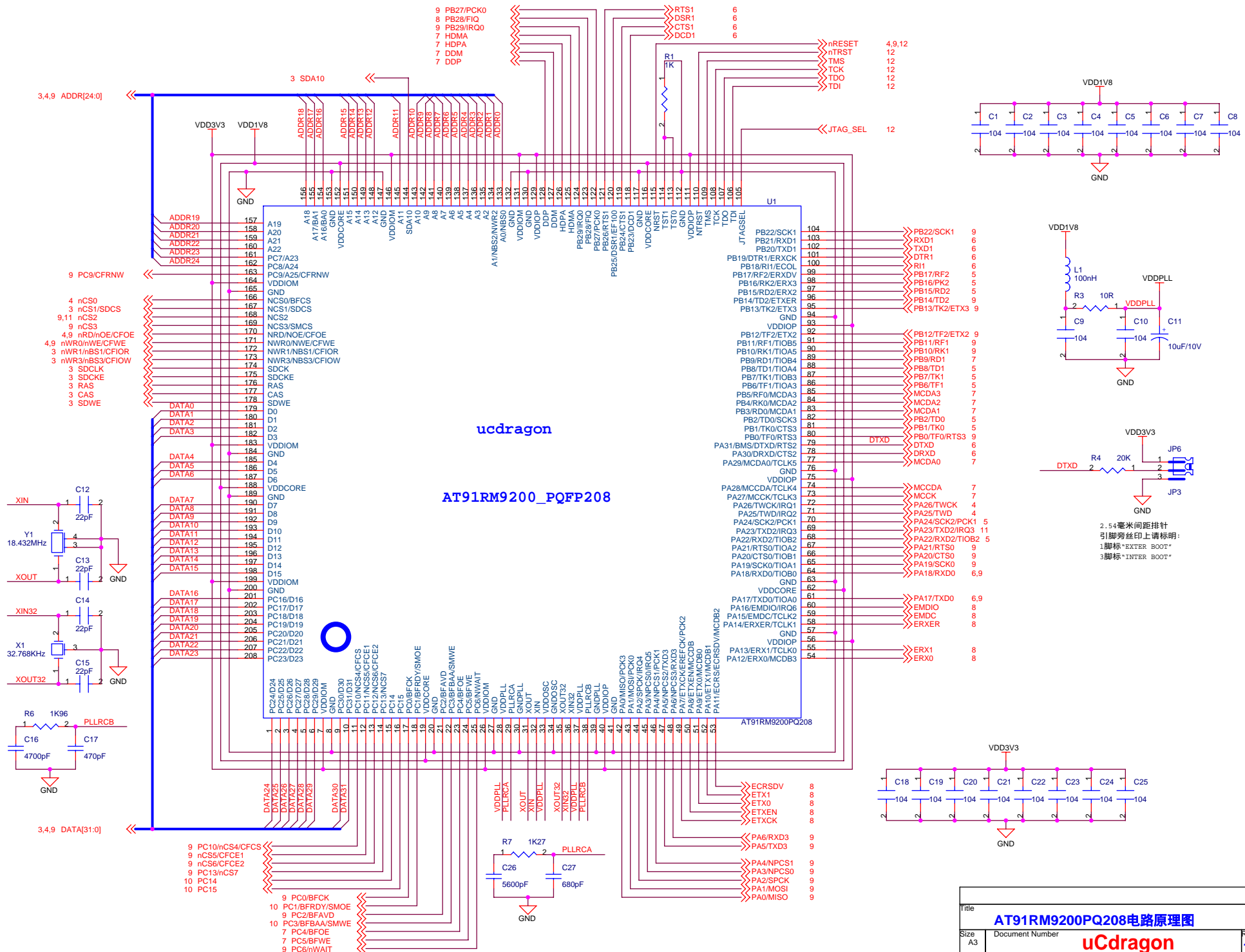

Title		
AT91RM9200PQ208电路原理图		
Size	Document Number	Rev
A3		uCdragon
Date:	Sunday, September 04, 2005	Sheet 2 of 13

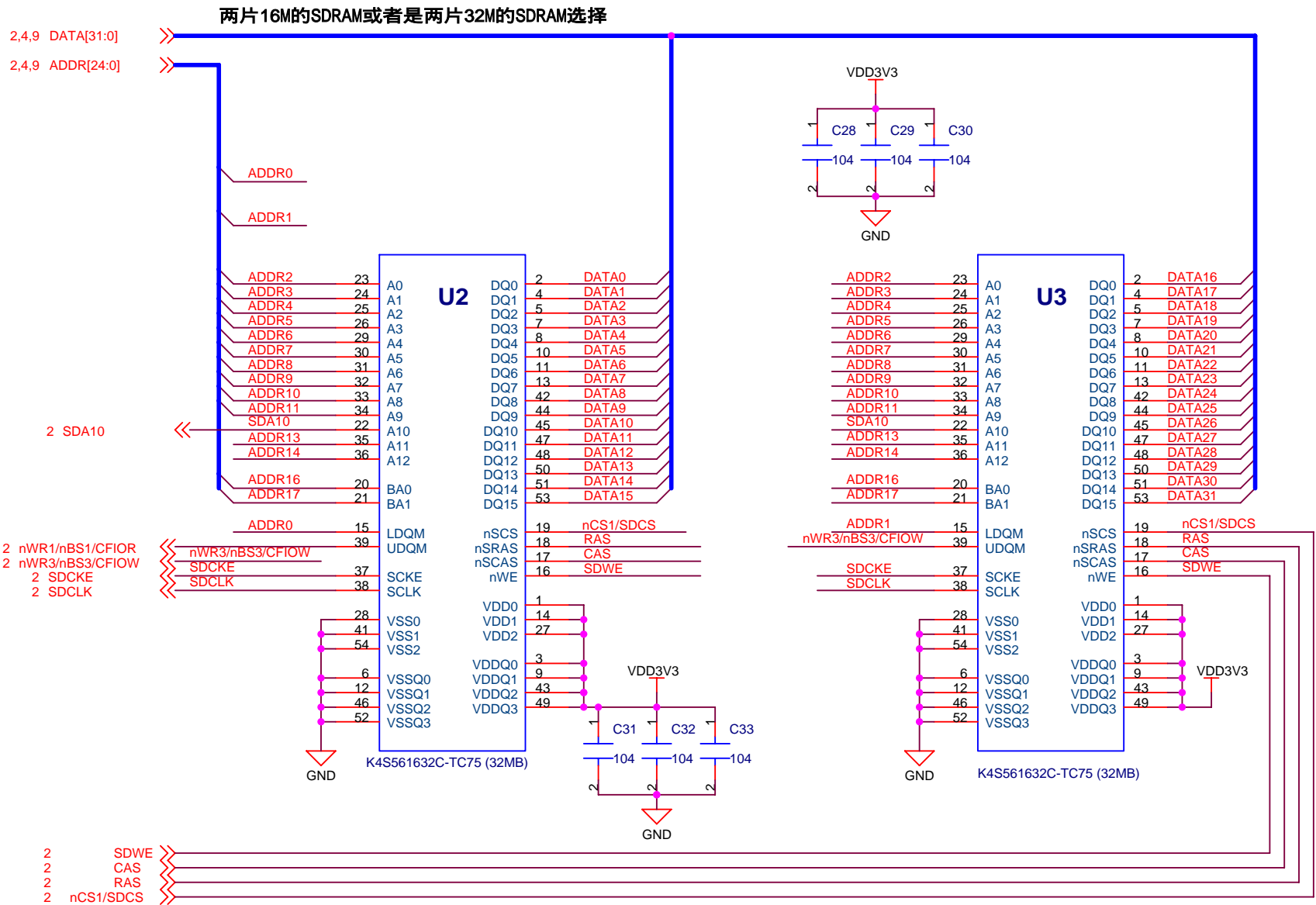

Title		
SDRAM接口电路原理图		
Size	Document Number	Rev
A4	uCdragon	1.0
Date:	Sunday, September 04, 2005	Sheet 3 of 13

Flash型号	引脚特性描述
PC28F320J3	3.3V供电, 4兆字节容量, 有效地址线A1 - A21;
PC28F640J3	3.3V供电, 8兆字节容量, 有效地址线A1 - A22;
PC28F128J3	3.3V供电, 16兆字节容量, 有效地址线A1 - A23;
PC28F256J3	3.3V供电, 32兆字节容量, 有效地址线A1 - A24;

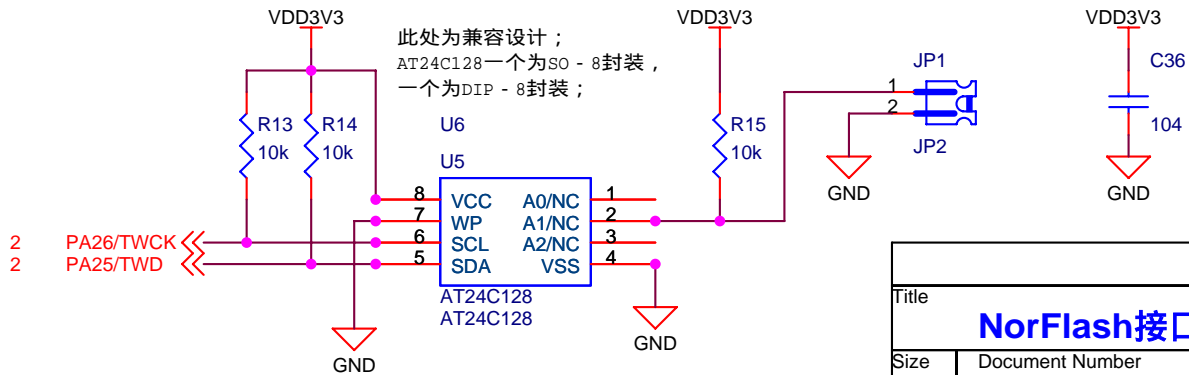
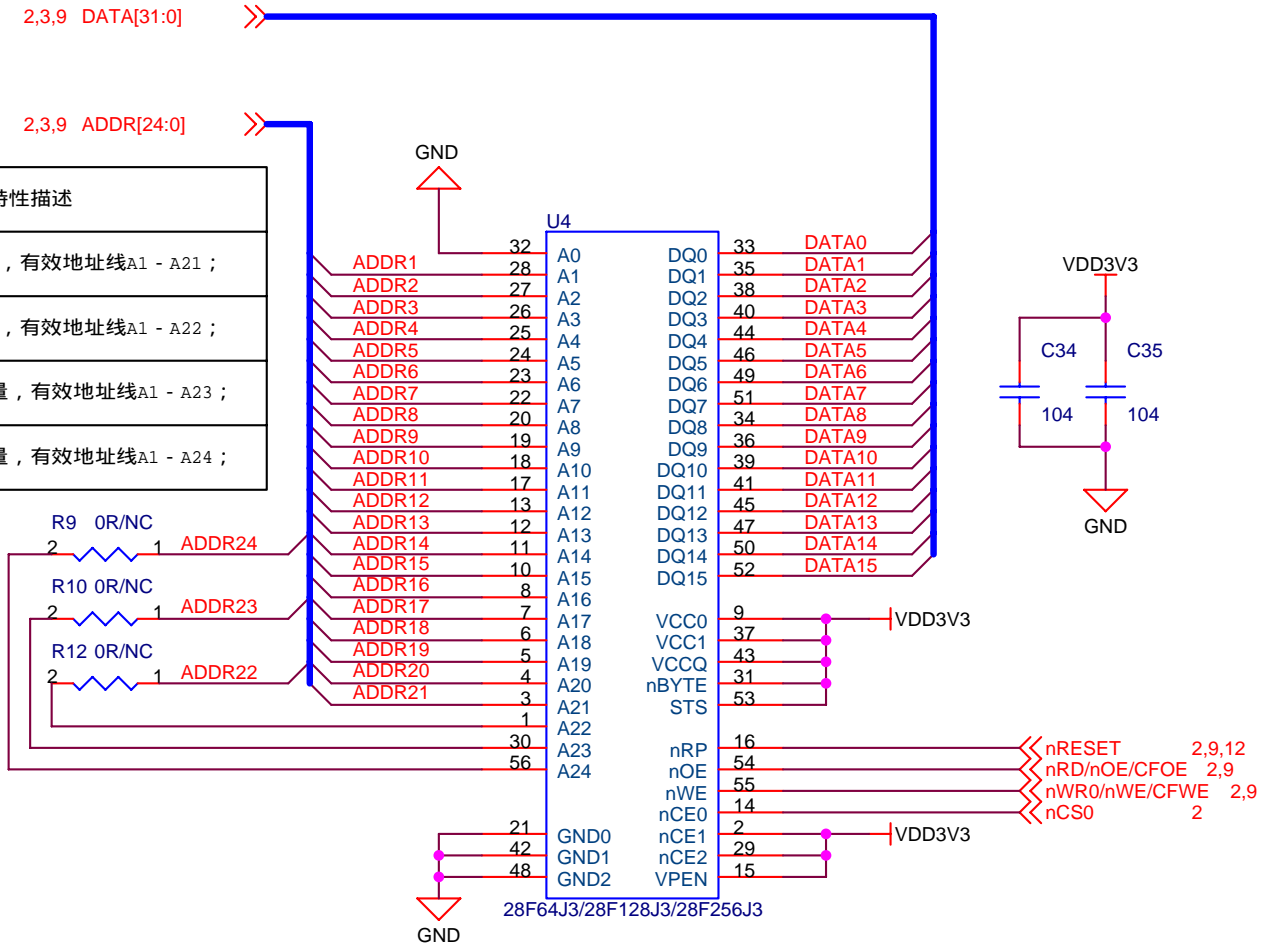

Title		
NorFlash接口电路原理图		
Size	Document Number	Rev
A	uCdragon	1.0
Date:	Sunday, September 04, 2005	Sheet 4 of 13

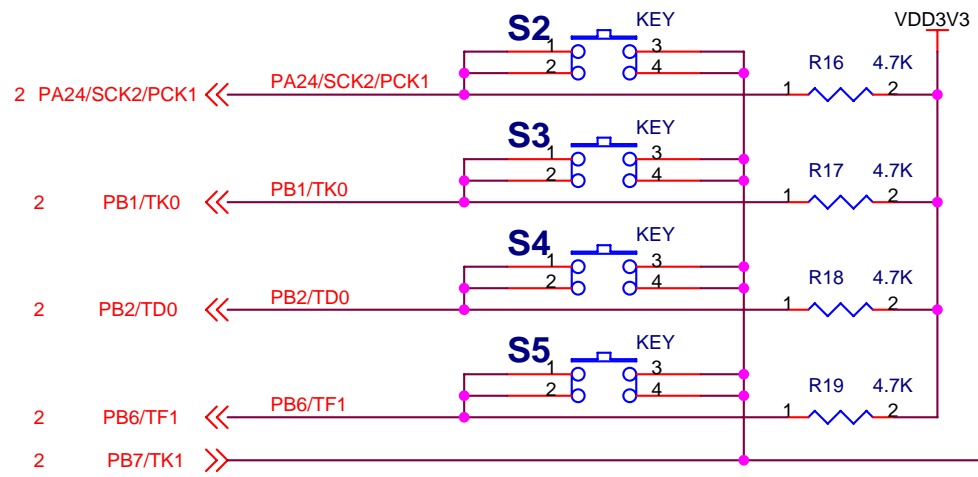

给用户扩展用的4x5矩阵键盘；
2毫米间距无座双排排针；
丝印上请标明第一脚和引脚序号；

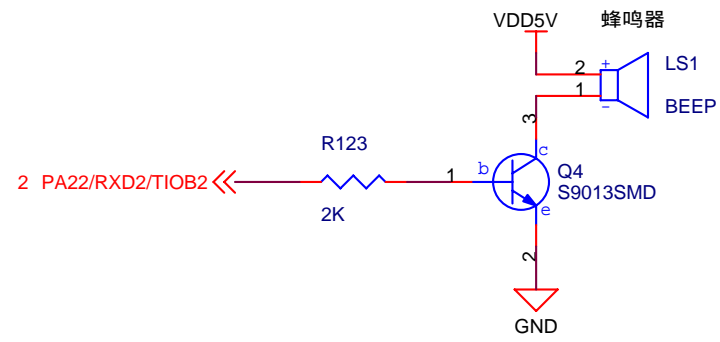
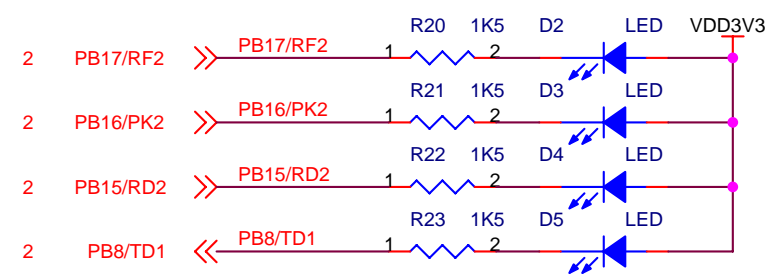
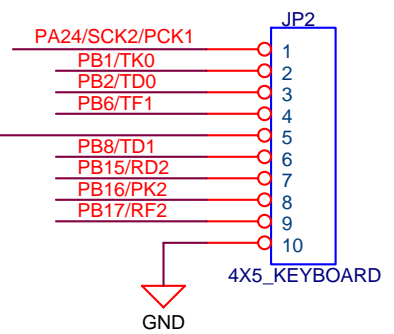

Title		
矩阵键盘、LED和蜂鸣器电路原理图		
Size A	Document Number	uCdragon
Date:	Sunday, September 04, 2005	Rev 1.0
Sheet 5 of 13		

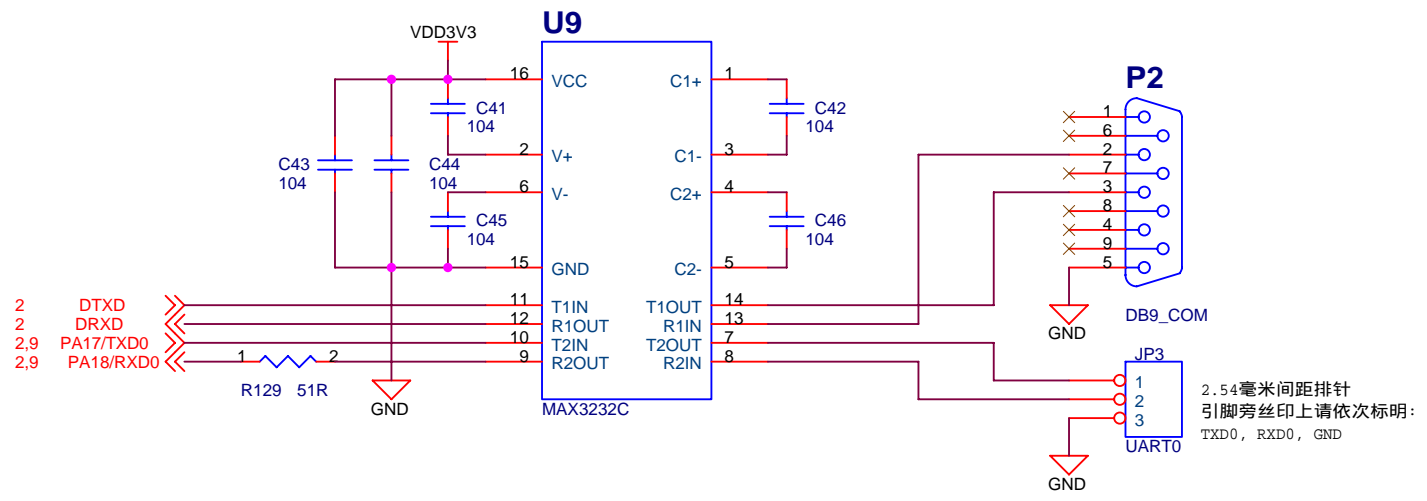
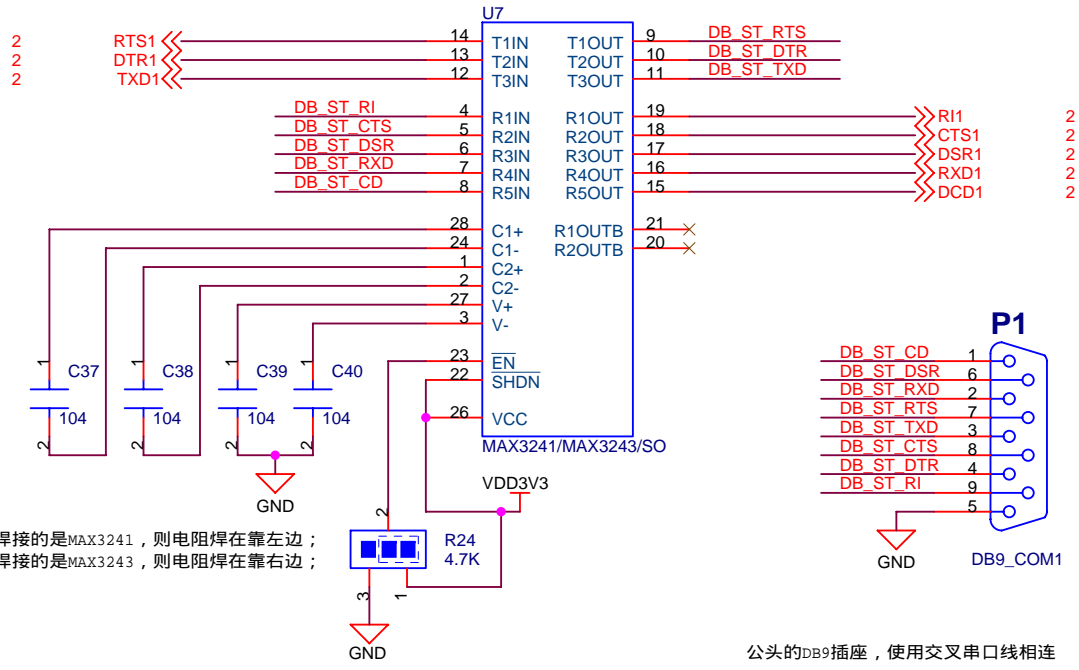

Title		
UART串口和RS485接口电路原理图		
Size A4	Document Number uCdragon	Rev 1.0
Date: Sunday, September 04, 2005	Sheet 6	of 13

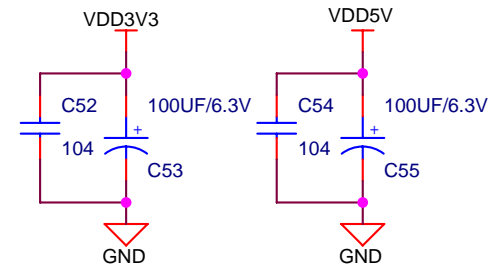
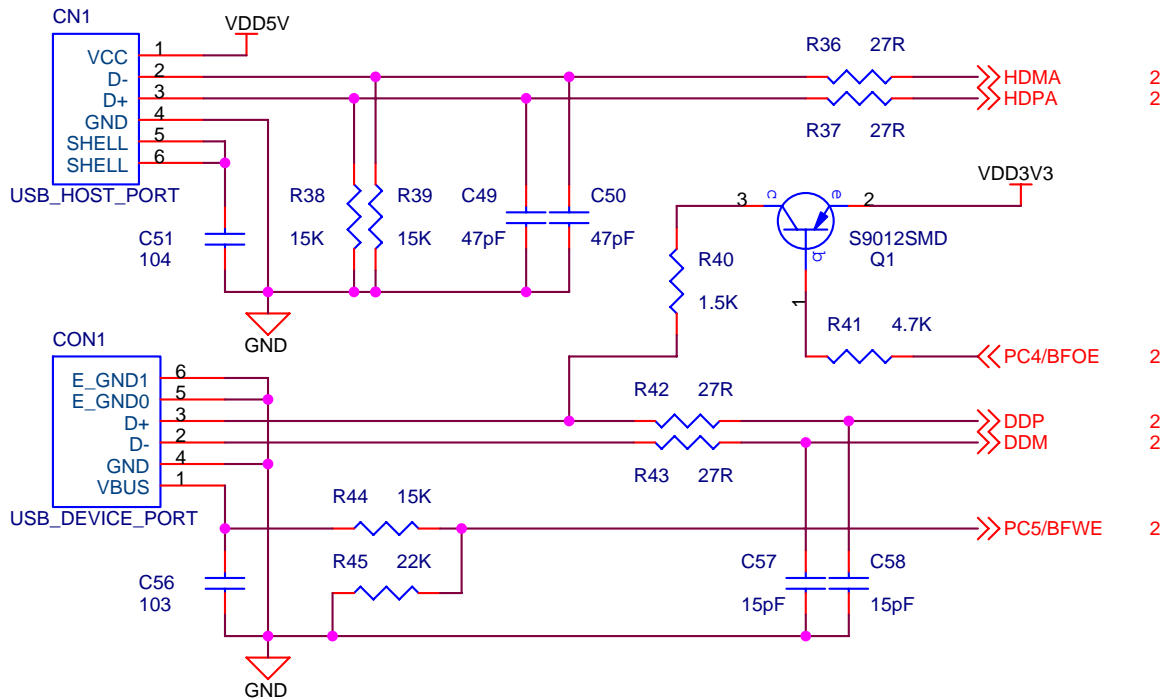
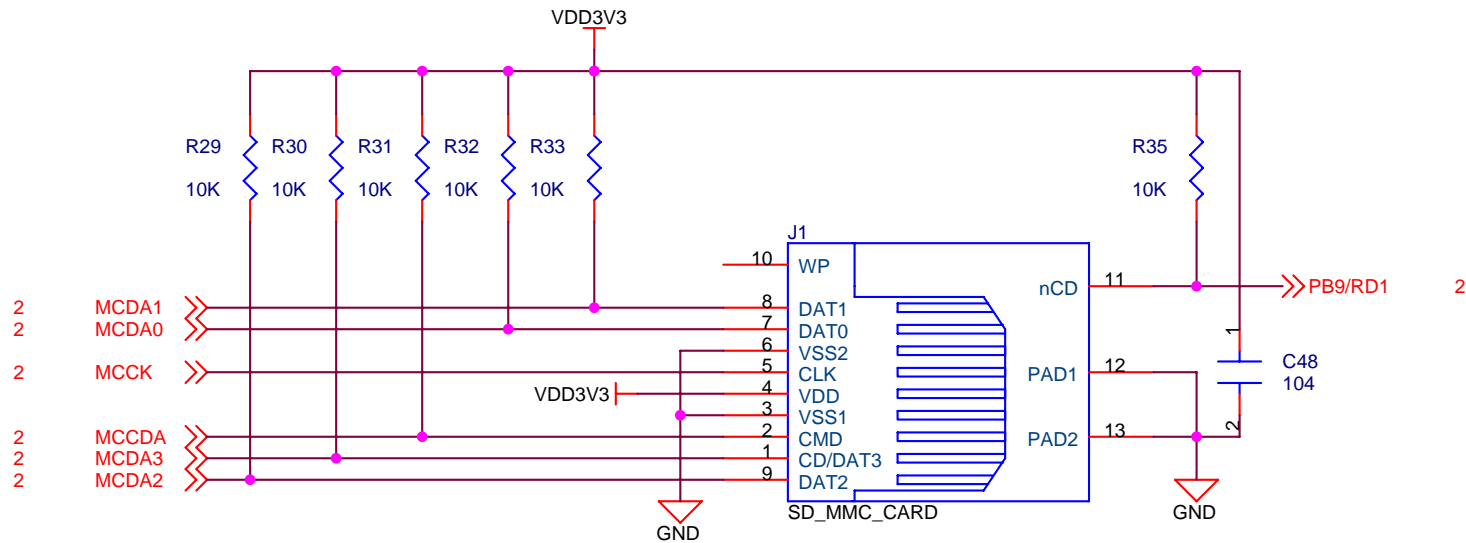

Title		
SD卡和USB接口电路原理图		
Size A	Document Number	uCdragon
Date:	Sunday, September 04, 2005	Sheet 7 of 13
		Rev 1.0

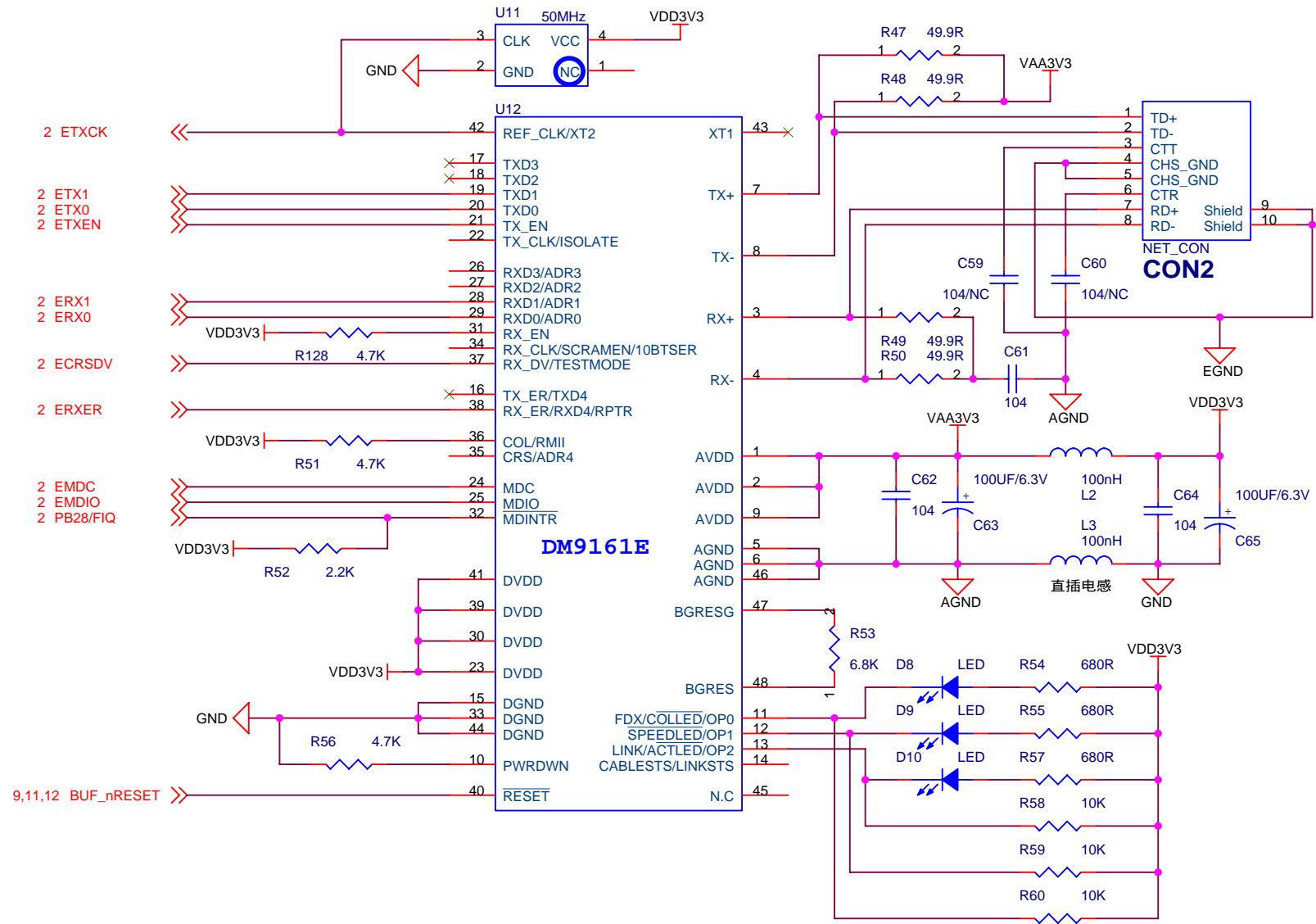

Title		100M以太网口DM9161E电路原理图	
Size	Document Number	uCdragon	
A4			
Date:	Sunday, September 04, 2005	Sheet	8 of 13
		Rev	1.0

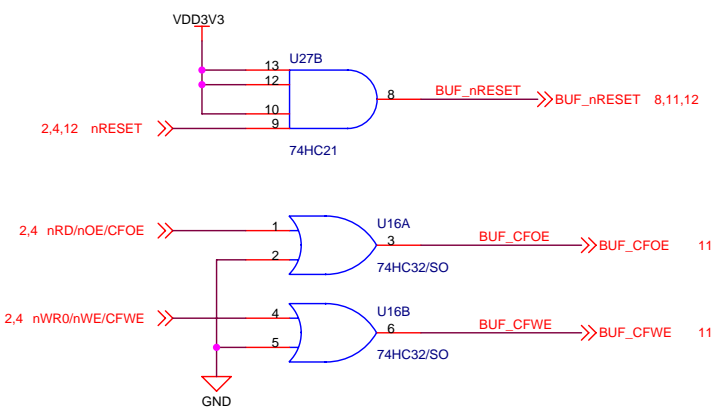
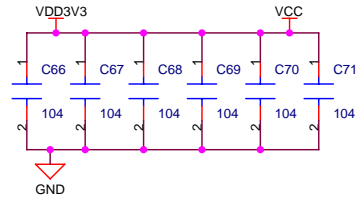
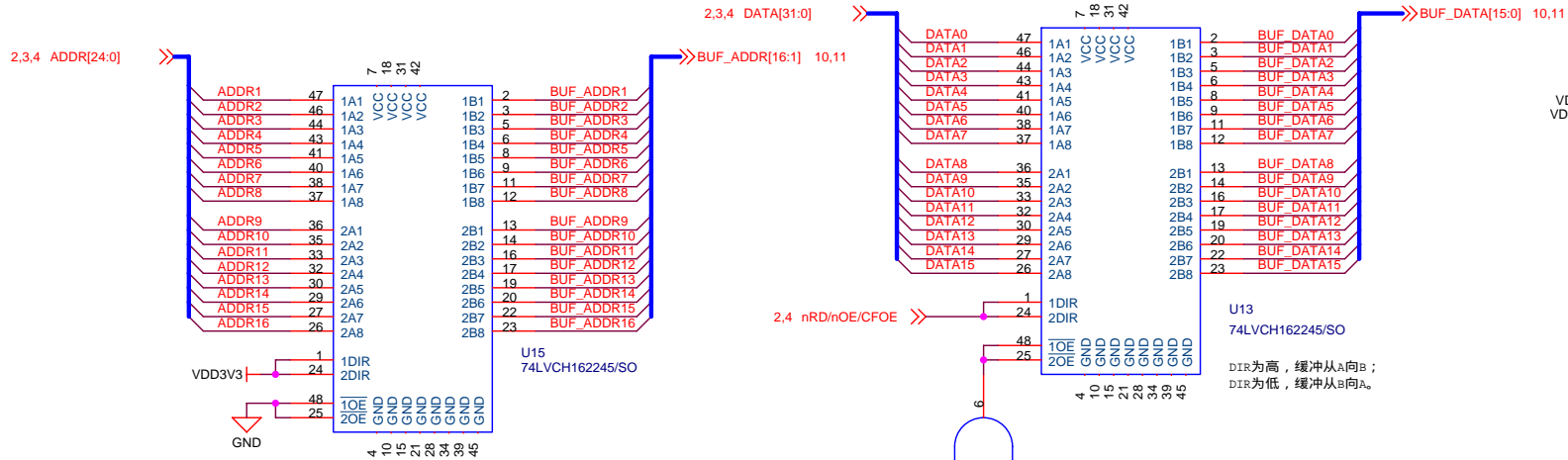

- 2,11 nCS2
- 2 nCS3
- 2 PC10/nCS4/CFCS
- 2 PC13/nCS7

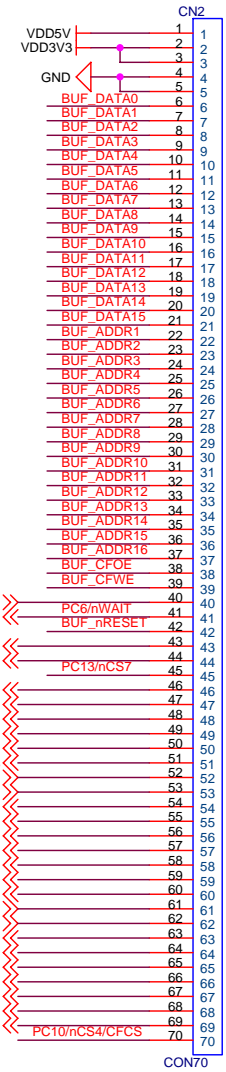

2毫米间距无源双排排针，丝印上请标明第一脚和引脚序号；

Title		
总线缓冲接口电路原理图		
Size	Document Number	Rev
B	uCdragon	1.0
Date:	Sunday, September 04, 2005	Sheet 9 of 13

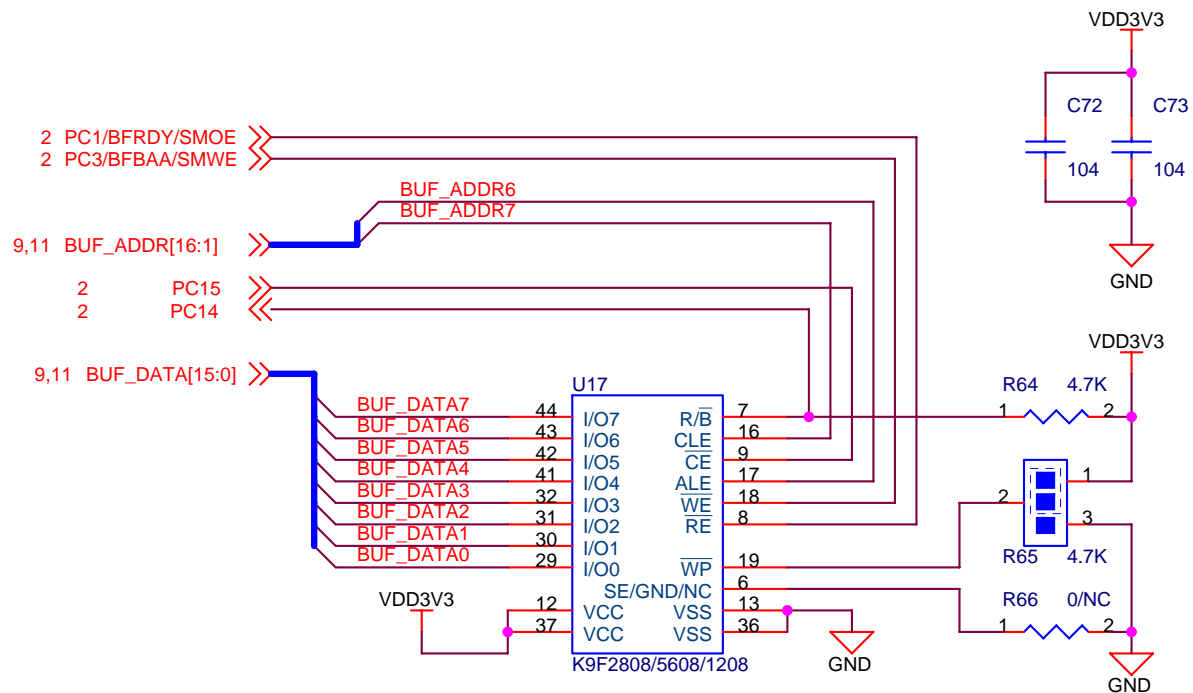

WP#接高电平允许擦除和写入；
 接低电平禁止擦除和写入。

Title		
NandFlash接口电路原理图		
Size A	Document Number	Rev 1.0
Date: Sunday, September 04, 2005		Sheet 10 of 13

2.54mm间距双排座子(筒牛座)
PCB要在座子旁边注明"IDE_CON"

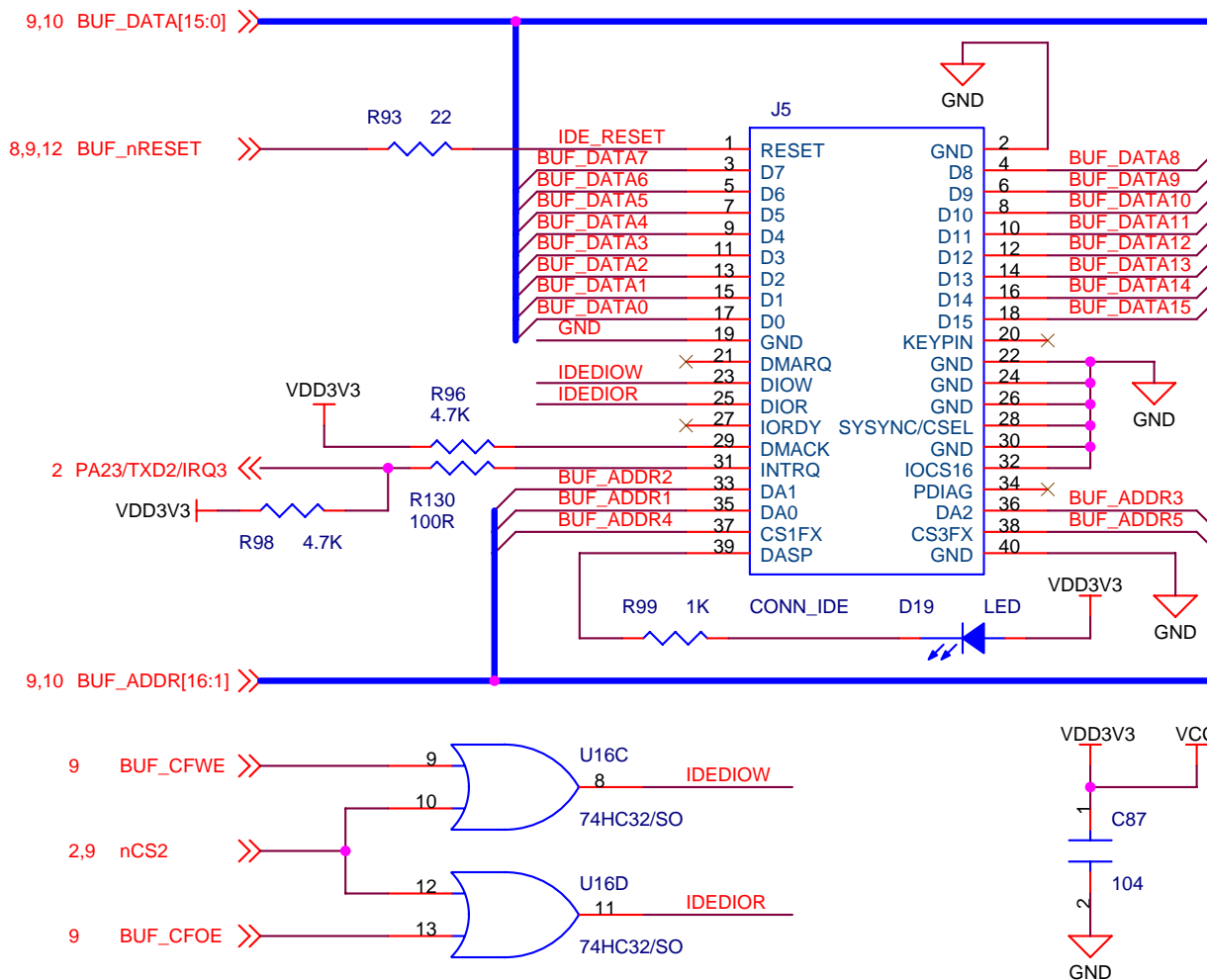

Title		
IDE硬盘接口电路原理图		
Size A	Document Number	Rev 1.0
Date:	Sunday, September 04, 2005	Sheet 11 of 13

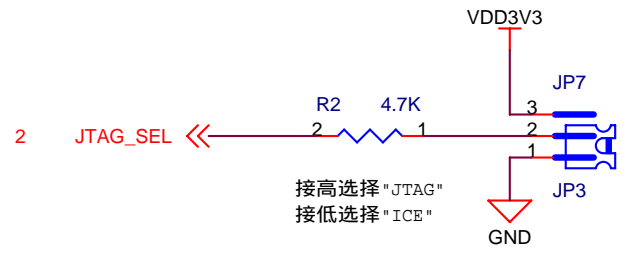
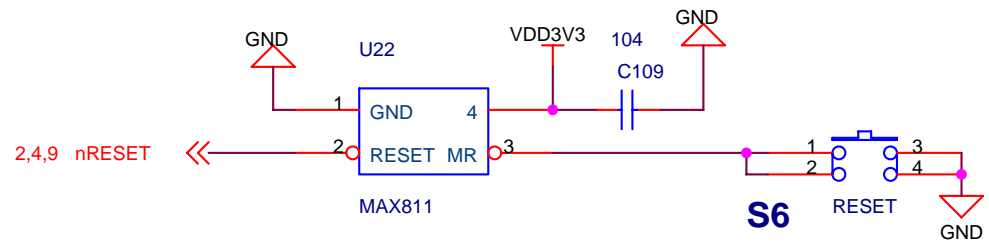
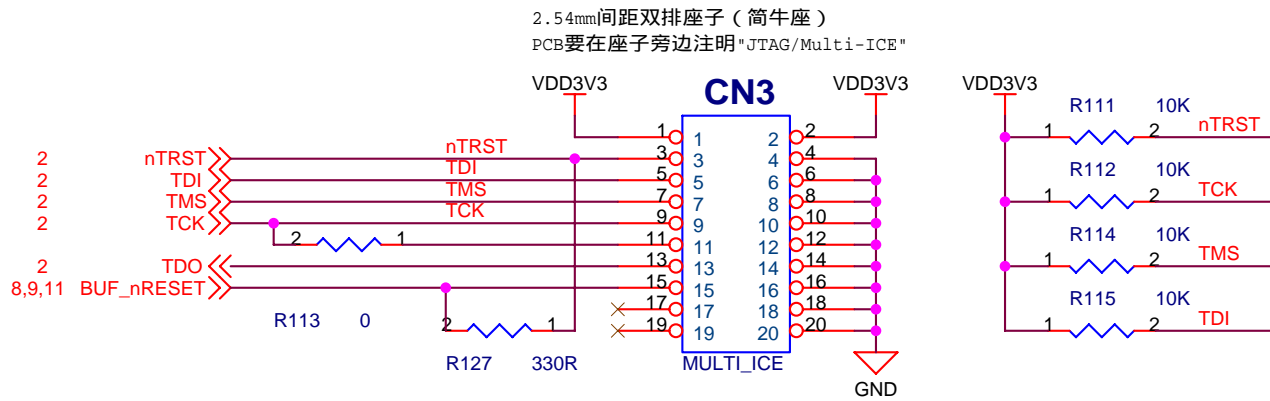

Title		
复位电路和JTAG接口电路原理图		
Size	Document Number	Rev
A	uCdragon	1.0
Date:	Sunday, September 04, 2005	Sheet 12 of 13

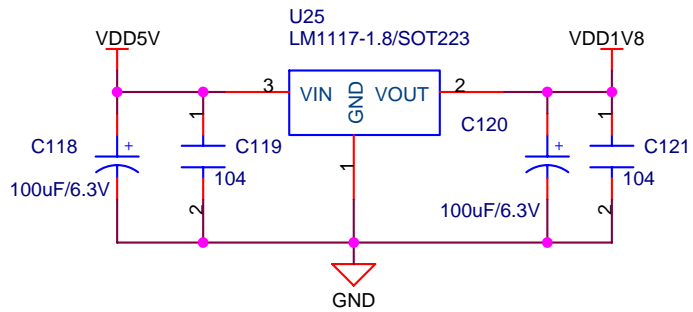
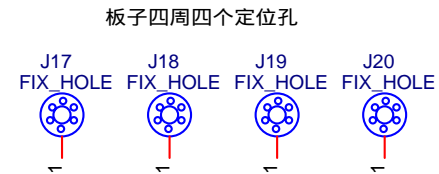
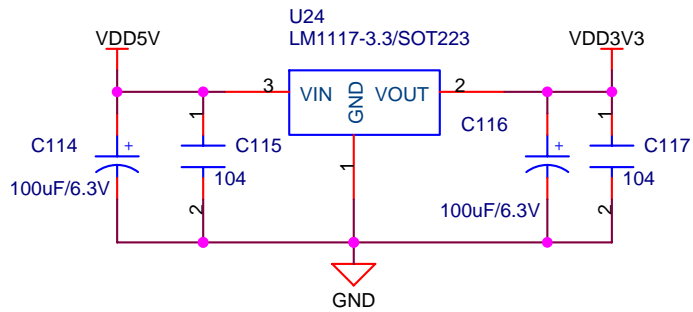
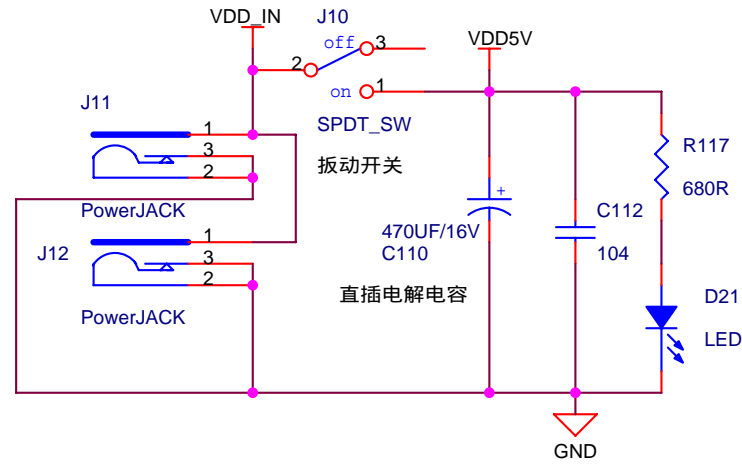

Title		
电源部分电路原理图		
Size A	Document Number	Rev 1.0
Date:	Sunday, September 04, 2005	Sheet 13 of 13