

AT91RM9200-EK Evaluation Board

.....

User Guide





Table of Contents

Section 1

Overview	1-1
1.1 Scope	1-1
1.2 Deliverables	1-2
1.3 The AT91RM9200-EK Evaluation Board	1-3

Section 2

Setting Up the AT91RM9200-EK Evaluation Board	2-1
2.1 Electrostatic Warning	2-1
2.2 Requirements	2-1
2.3 Powering Up the Board	2-1
2.4 Getting Started with the AT91RM9200	2-1

Section 3

Board Description	3-1
3.1 AT91RM9200 Processor	3-1
3.2 Memory	3-2
3.3 Memory Card	3-2
3.4 Clock Circuitry and Analog Functions	3-2
3.5 Reset Circuitry	3-2
3.6 Power Supply Circuitry	3-2
3.7 Remote Communication	3-2
3.8 User Interface	3-2
3.9 Expansion Slot	3-3
3.10 Debug Interface	3-3
3.11 Wrapping User Area	3-3

Section 4

Configuration Straps	4-1
4.1 Configuration Straps and Jumper Settings	4-1

Section 5

Schematics	5-1
5.1 Schematics	5-1



Section 1

Overview

1.1 Scope

The AT91RM9200-EK Evaluation Board enables real-time code development and evaluation. It supports the AT91RM9200 ARM9™-based 32-bit RISC microcontroller.

This guide focuses on the AT91RM9200-EK Evaluation Board as an evaluation and demonstration platform:

- Section 1 is this overview.
- Section 2 gives information on setting up the installation.
- Section 3 contains a description of the development board.
- Section 4 details the configuration straps.
- Section 5 shows board schematics.

1.2 Deliverables

The development kit is delivered with:

- One AC adapter 100 - 240V ~ 1.2A, 12V, 50 - 60 Hz with adapters
 - One modem RS232 cable
 - One RJ45 Ethernet crossed cable
 - One A/B-type USB cable
 - One AT91 DVD-ROM containing summary and full datasheets, datasheets with electrical and mechanical characteristics, application notes and getting started documents for all development boards and AT91 microcontrollers. An AT91 software package with C and assembly listings is also provided. This allows the user to begin evaluating the AT91 ARM® Thumb® 32-bit microcontroller quickly.
 - CD ROMs from third parties, providing solutions for operating system evaluation
 - DataFlash® Cards to provide demonstrations of operating systems when inserted in the bootable slot
- Note:** To boot on a DataFlash Card:
- Ensure J15 (BMS) is set on position 1-2
 - Insert the DataFlash Card in the J200 socket (bottom side)
 - Reset the board

Further details are given on the AT91 DVD-ROM.

Note: These deliverables are subject to change without notice.

1.3

**The
AT91RM9200-EK
Evaluation Board**

The board consists of an AT91RM9200 together with the following:

- 8 Mbytes of parallel Flash memory
- Four banks of 2M x 32-bit SDRAM
- DataFlash[®] or SD/MMC memory expansion socket
- Additional DataFlash memory expansion socket
- Digital-to-Analog Converter (DAC) for a stereo audio signal
- Four communication ports (USB host and device, Ethernet, serial and DBGU)
- Graphic controller with output to a standard VGA monitor
- JTAG/ICE, ETM and code test port interface
- Expansion connector
- Onboard prototype area

Figure 1-1. AT91RM9200-EK Evaluation Board Block Diagram

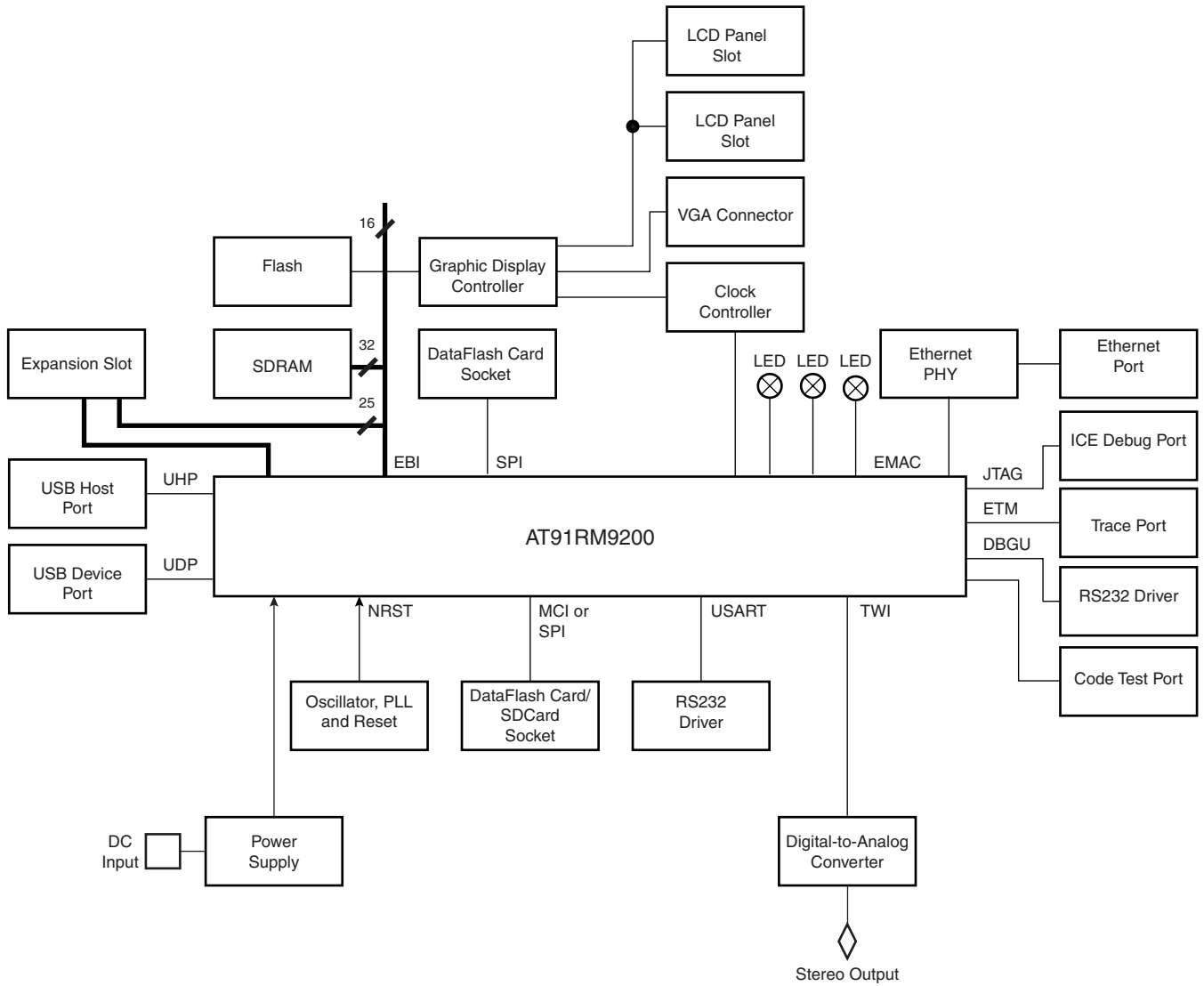



Section 2

Setting Up the AT91RM9200-EK Evaluation Board

-
- | | | |
|------------|--|--|
| 2.1 | Electrostatic Warning | The AT91RM9200-EK Evaluation Board is shipped in protective anti-static packaging. The board must not be subjected to high electrostatic potentials. A grounding strap or similar protective device should be worn when handling the board. Avoid touching the component pins or any other metallic element. |
| <hr/> | | |
| 2.2 | Requirements | <p>In order to connect the AT91RM9200-EK Evaluation Board, the following element is required:</p> <ul style="list-style-type: none">■ The AT91RM9200-EK Evaluation Board itself |
| <hr/> | | |
| 2.3 | Powering Up the Board | <p>DC power is supplied to the board via the 2.1 mm socket (J1). The polarity of the power supply is not critical. The minimum voltage required is 7V.</p> <p>The board has a voltage regulator providing +3.3V. The regulator allows the input voltage range to be from 7V to 12V.</p> |
| <hr/> | | |
| 2.4 | Getting Started with the AT91RM9200 | The AT91RM9200-EK Evaluation Board is delivered with a DVD-ROM containing all necessary information and step-by-step procedures for working with the most common development tool chains. Please refer to this DVD-ROM, or to the AT91 web site, http://www.atmel.com/products/AT91/ , for the most up-to-date information on getting started with the AT91RM9200. |





Section 3

Board Description

- 3.1 AT91RM9200 Processor**
- Incorporates the ARM920T™ ARM® Thumb® Processor
 - 200 MIPS at 180 MHz
 - 16-KByte Data Cache, 16-KByte Instruction Cache, Write Buffer
 - Memory Management Unit
 - In-circuit Emulator including Debug Communication Channel
 - Mid-level Implementation Embedded Trace Macrocell
 - Additional Embedded Memories
 - 16K Bytes of SRAM and 128K Bytes of ROM
 - External Bus Interface (EBI)
 - Supports SDRAM, Static Memory, Burst Flash, Glueless Connection to CompactFlash®, SmartMedia™ and NAND Flash
 - System Peripherals:
 - Enhanced Clock Generator and Power Management Controller
 - Two On-chip Oscillators with Two PLLs
 - Very Slow Clock Operating Mode and Software Power Optimization Capabilities
 - Four Programmable External Clock Signals
 - System Timer Including Periodic Interrupt, Watchdog and Second Counter
 - Real-time Clock with Alarm Interrupt
 - Debug Unit, Two-wire UART and Support for Debug Communication Channel
 - Advanced Interrupt Controller with 8-level Priority, Individually Maskable Vectored Interrupt Sources, Spurious Interrupt Protected
 - Seven External Interrupt Sources and One Fast Interrupt Source
 - Four 32-bit PIO Controllers with Up to 122 Programmable I/O Lines, Input Change Interrupt and Open-drain Capability on Each Line
 - 20-channel Peripheral DMA Controller (PDC)
 - Ethernet MAC 10/100 Base-T
 - USB 2.0 Full Speed (12 M-bits per second) Host Double Port and Device Port

- MultiMedia Card Interface (MCI)
- Three Synchronous Serial Controllers (SSC)
- Four Universal Synchronous/Asynchronous Receiver/Transmitters (USART)
- Master/Slave Serial Peripheral Interface (SPI)
- Two 3-channel, 16-bit Timer/Counters (TC)
- Two-wire Interface (TWI)
- IEEE 1149.1 JTAG Boundary Scan on All Digital Pins

-
- 3.2 Memory**
- 8-Mbyte parallel Flash memory
 - Four banks of 2M x 32-bit SDRAM

-
- 3.3 Memory Card**
- SD Card/MMC
 - Supports MultiMedia and SD Card
 - Analog switches provide support for DataFlash[®] Card
 - Additional DataFlash Card Socket

-
- 3.4 Clock Circuitry and Analog Functions**
- 32.768 kHz standard crystal for the AT91RM9200
 - 18.432 MHz standard crystal for the AT91RM9200
 - 50 MHz CMOS oscillator for the Display Controller and Ethernet PHY

-
- 3.5 Reset Circuitry**
- Reset Controller

-
- 3.6 Power Supply Circuitry**
- 3.3V DC/DC converter
 - 1.8V DC/DC converter

-
- 3.7 Remote Communication**
- Fast Ethernet Physical Layer Single Chip Transceiver
 - Host Interface via RS-232 DB9 male socket
 - Debug Port via RS-232 DB9 connector
 - Host and Device USB socket

-
- 3.8 User Interface**
- Graphic Display Controller
 - TFT/SNT panel socket
 - 15-pin standard socket for an external VGA monitor

- Three LEDs managed via general PIO lines
- Stereo Audio Jack connected to a DAC

3.9 Expansion Slot ■ The expansion slot gives access to all the microcontroller's signals.

3.10 Debug Interface

- 38-pin trace Port socket (ETM)
- 38-pin Code Test port socket
- 20-pin JTAG ICE interface connector
- Serial Debug Unit

3.11 Wrapping User Area ■ Onboard prototype area allowing the developer to fit additional components.





Section 4

Configuration Straps

4.1 Configuration Straps and Jumper Settings

Table 4-1 gives details on configuration straps and jumper settings on the AT91RM9200-EK Evaluation Board and their default settings.

Table 4-1. Configuration Straps and Jumper Settings

Designation	Default Setting	Feature
J13	Closed	Available for measuring VDDCORE current.
J15	1 - 2	The AT91RM9200 boots from internal ROM and can also boot from external SPI DataFlash [®] connected on NPCSO.
	2 - 3	The AT91RM9200 boots from Flash memory connected on NCS0.





Section 5

Schematics

5.1 Schematics

This section contains the following schematics:

- AT91RM9200-EK Board Layout - Top View
- AT91RM9200-EK Board Layout - Bottom View
- Power Supply
- AT91RM9200 Chip
- Debug
- SDRAM and Flash
- RMI Ethernet
- Stereo Audio DAC
- Serial Interfaces
- VGA Display
- Expansion Connector

Figure 5-1. AT91RM9200-EK Board Layout - Top View

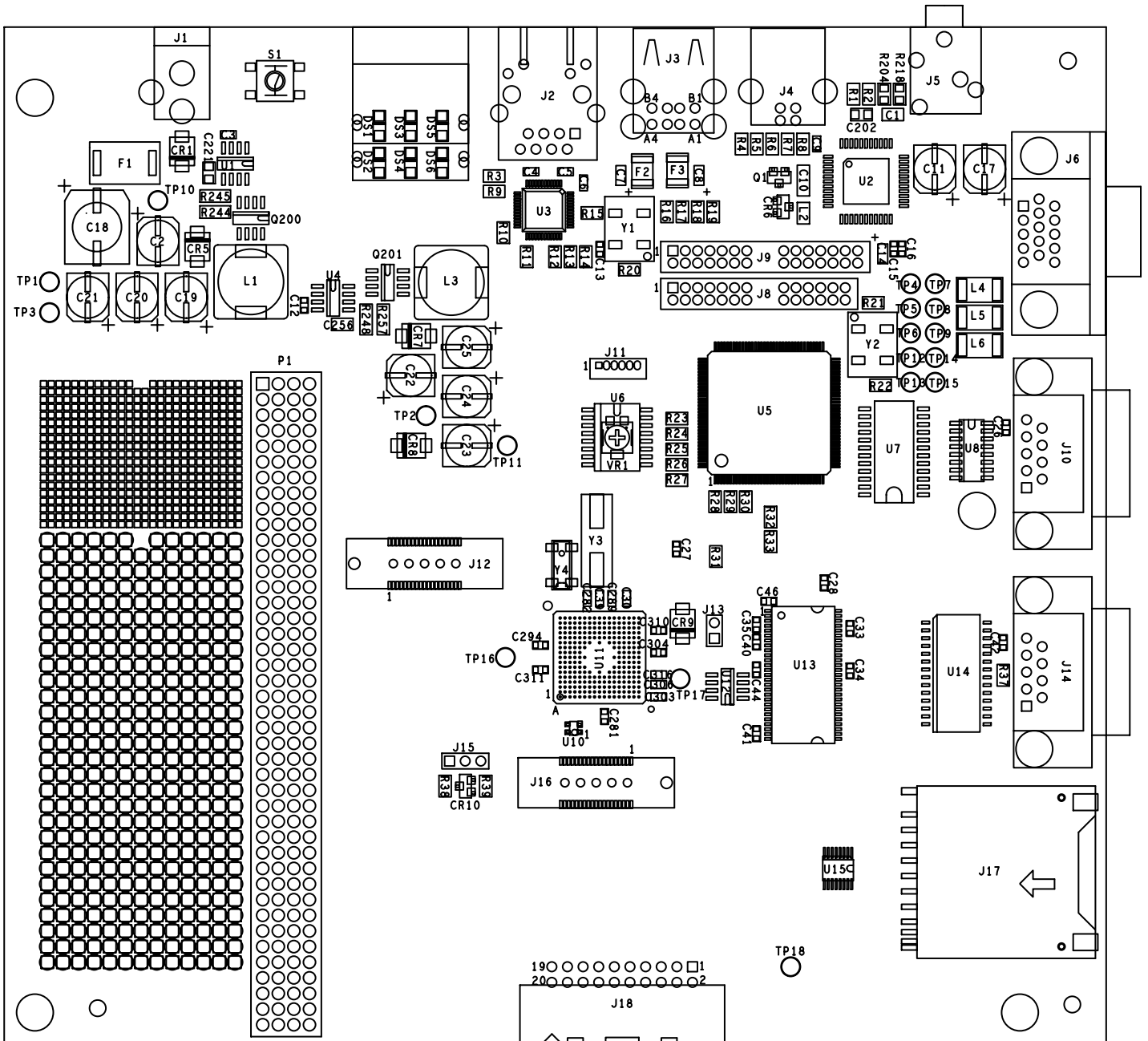
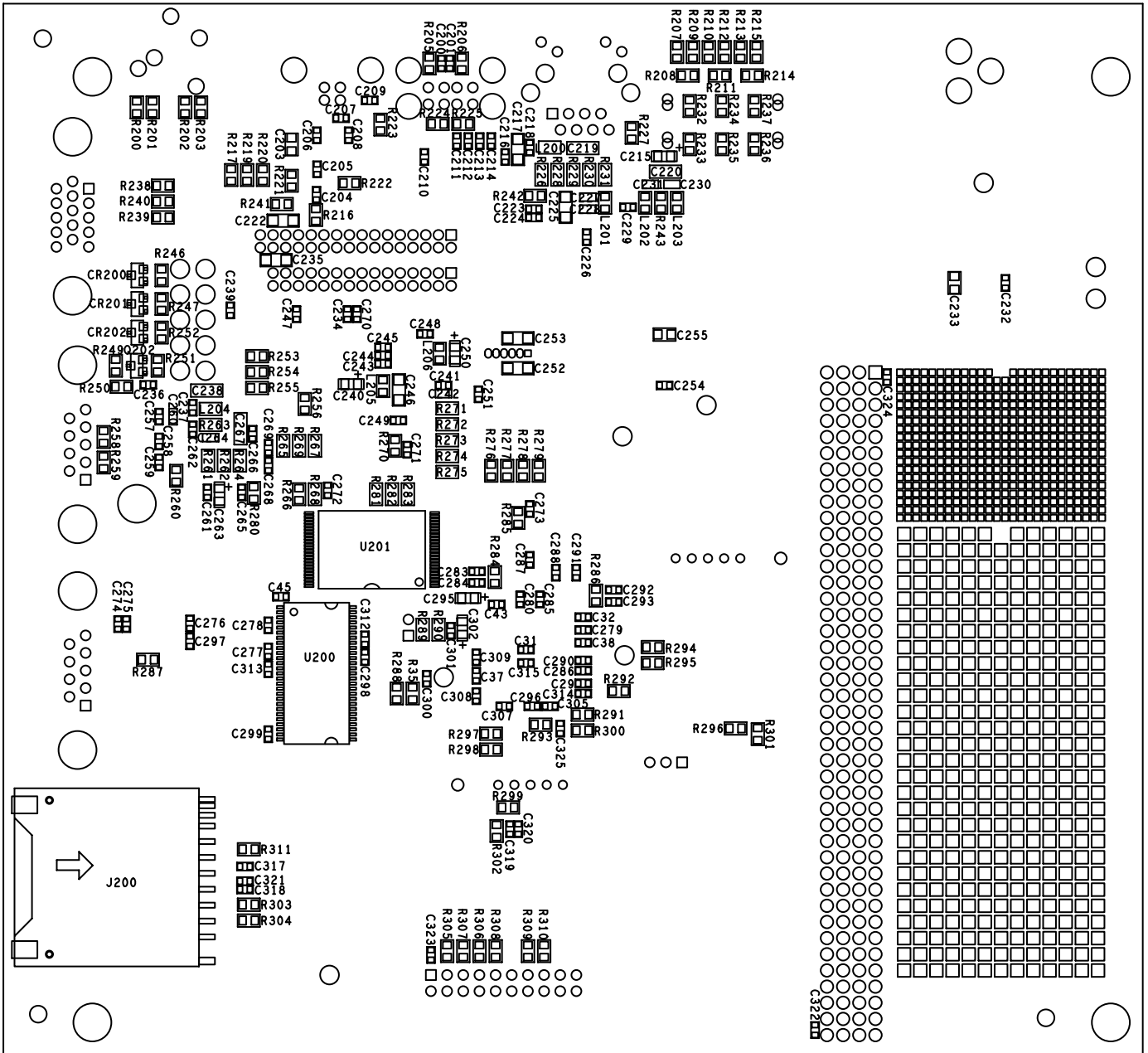
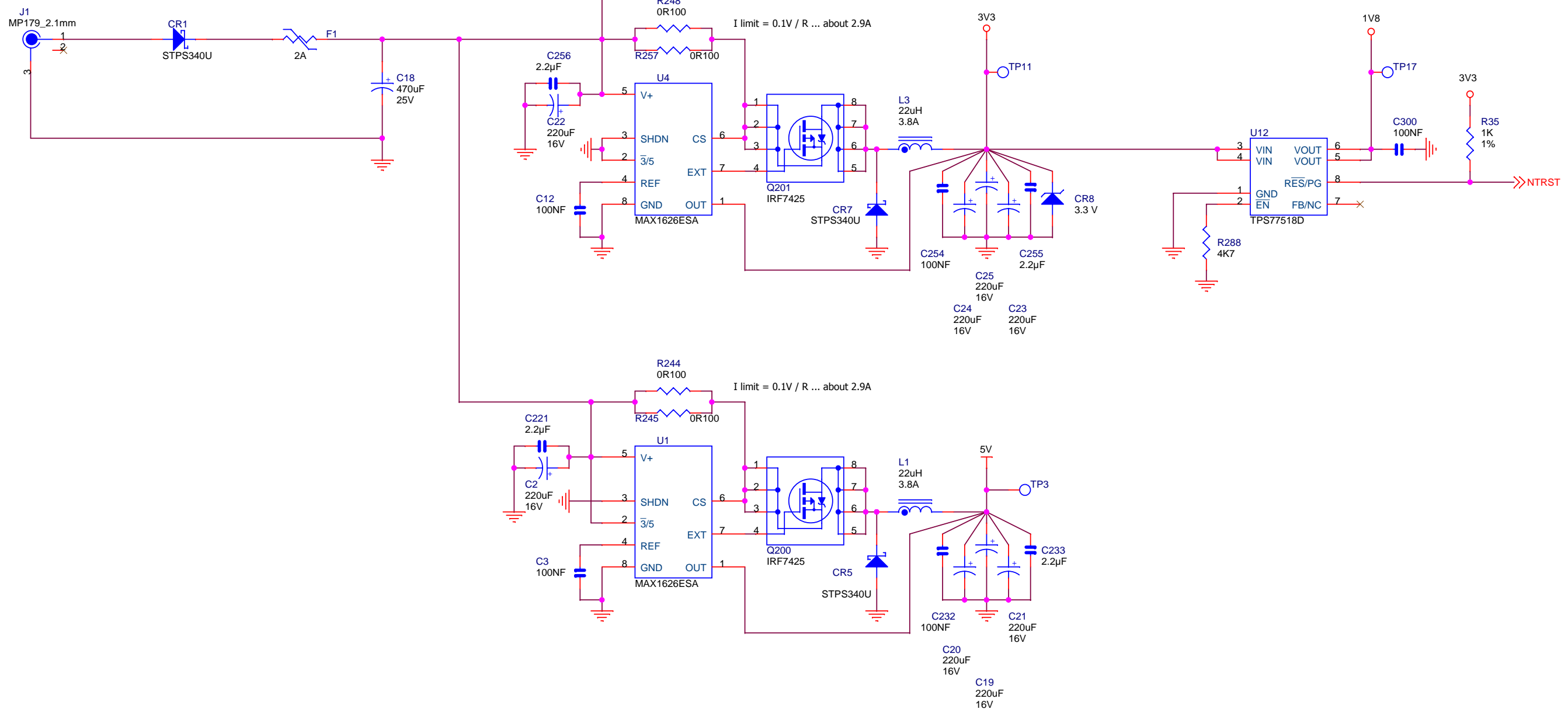

Figure 5-2. AT91RM9200-EK Board Layout - Bottom View



12V TO 14V DC INPUT



Z3 - Z5 are mounting holes.
The Z reference designators
are not listed on the actual
board.

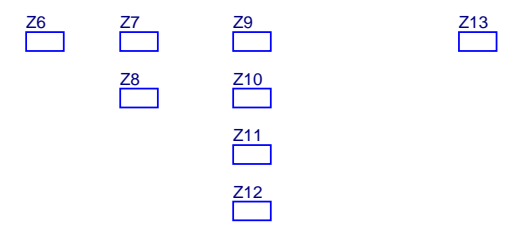
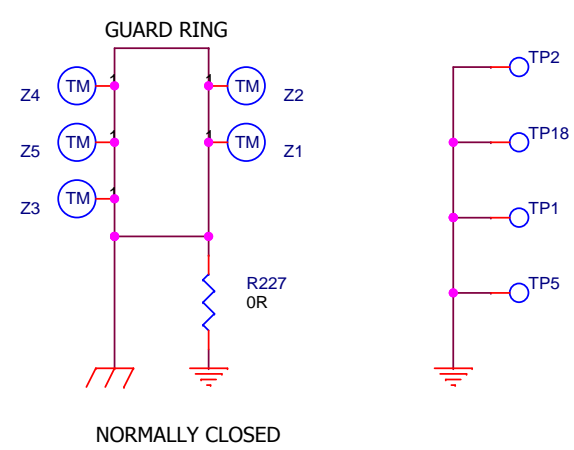

Monday, March 21, 2005

ATMEL ROUSSET		A01 101-3-05-106		ELX	23/02/05	JPG	23/02/05
AT91RM9200-EK		A	INIT EDIT	MDZ	04/01/05	JPG	06/01/05
POWER SUPPLY		REV	MODIF.	DES.	DATE	VER.	DATE
SCALE 1/1		63SC042261A01		REV.	SHEET		1/9

This agreement is our property. Reproduction and publication without our written authorization shall expose offender to legal proceedings.

AT91RM9200

U11

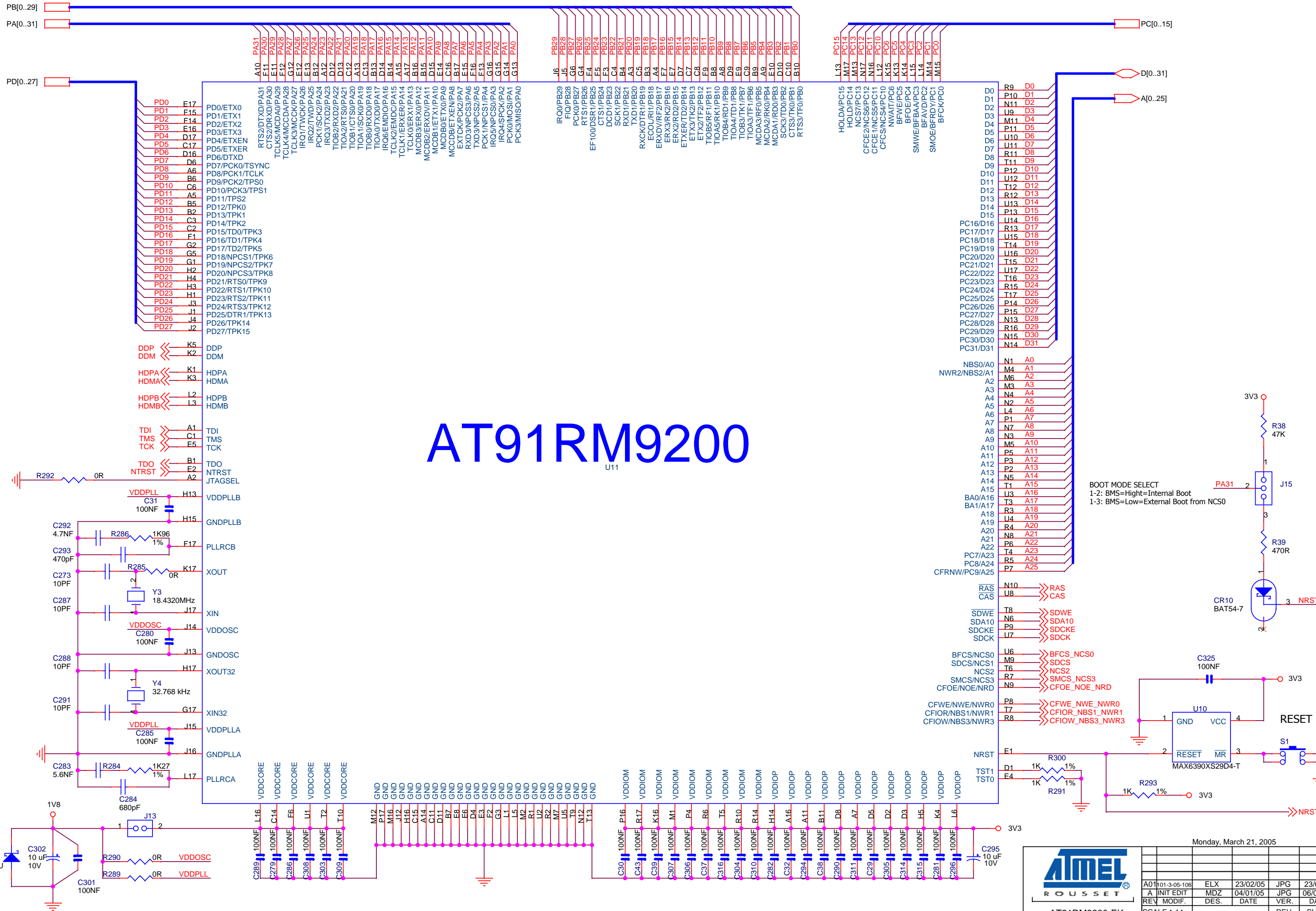

BOOT MODE SELECT
1-2: BMS=High=Internal Boot
1-3: BMS=Low=External Boot from NCS0

Monday, March 21, 2005

ATMEL ROUSSET			
A01101-3-05-106	ELX	23/02/05	JPG
A INIT EDIT	MDZ	04/01/05	JPG
REV	MODIF.	DES.	DATE
SCALE 1/1			REV.
AT91RM9200-EK		63SC042261A01	
AT91RM9200		SHEET 2/9	

This agreement is our property. Reproduction and publication without our written authorization shall expose offender to legal proceedings.

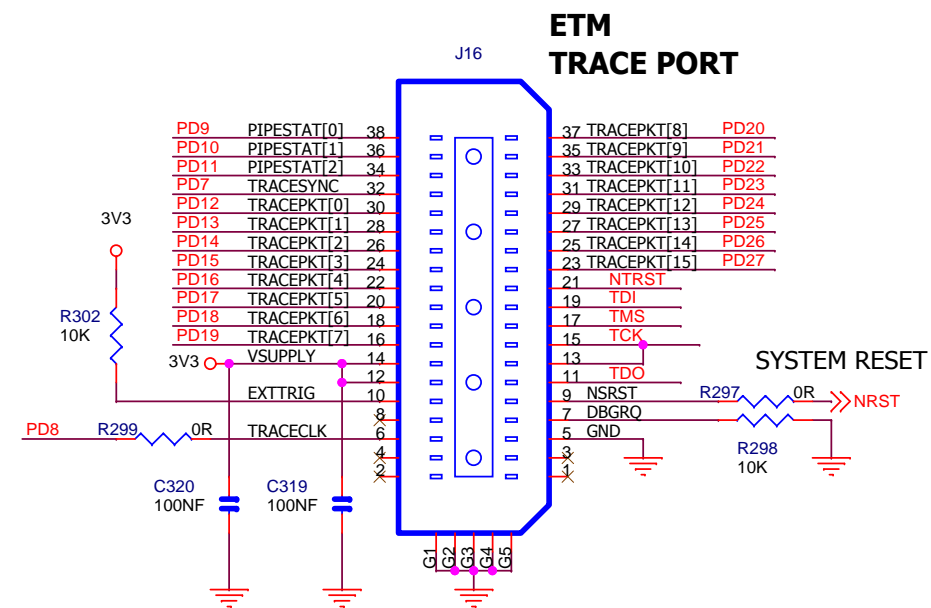
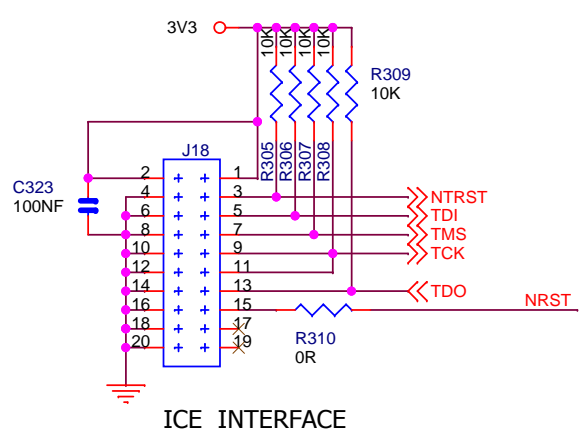
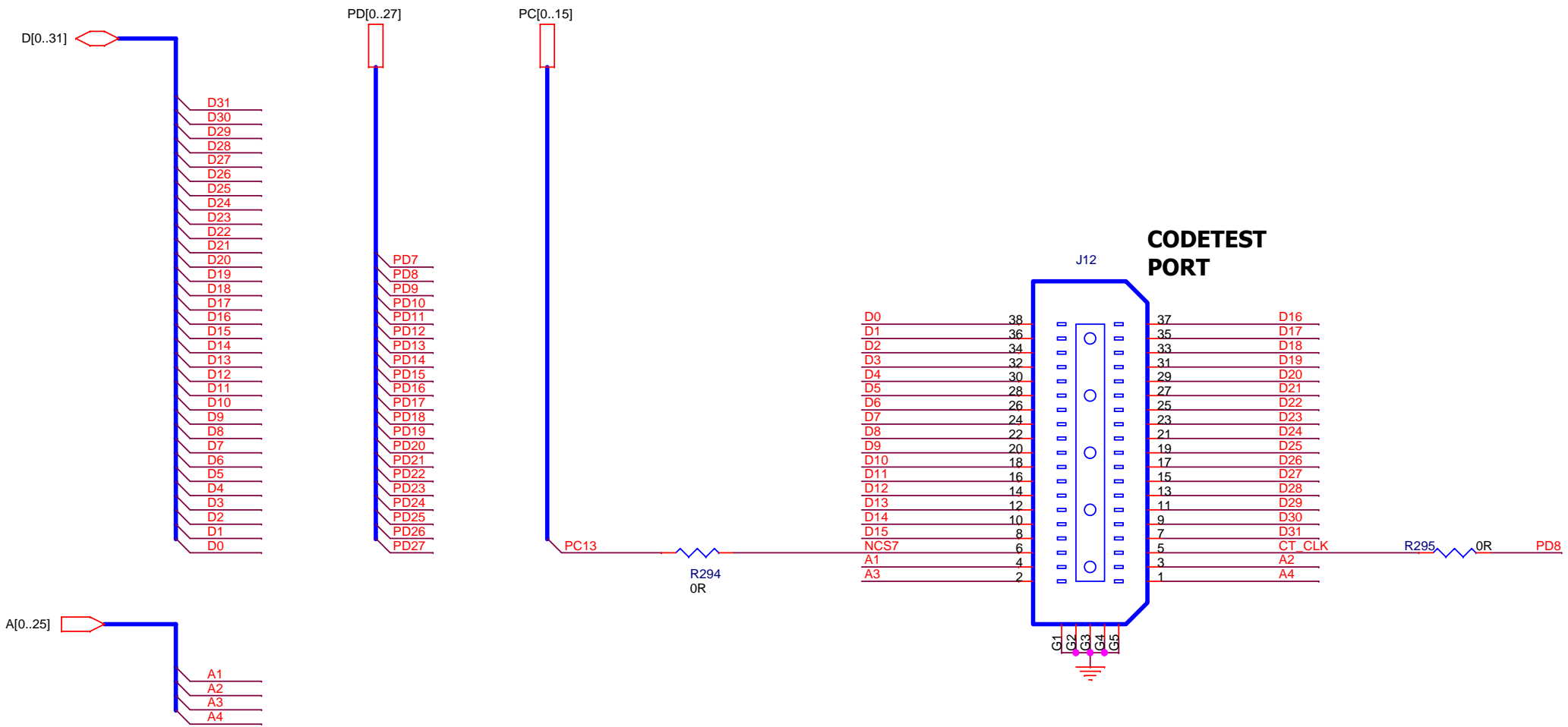

Monday, March 21, 2005

		A01	01-3-05-106	ELX	23/02/05	JPG	23/02/05
AT91RM9200-EK		REV	MODIF.	DES.	DATE	VER.	DATE
ETM - ICE - TEST		SCALE	1/1	63SC04226		REV.	SHEET
				A01		3/9	

This agreement is our property. Reproduction and publication without our written authorization shall expose offender to legal proceedings.

EBI SDRAM INTERFACE

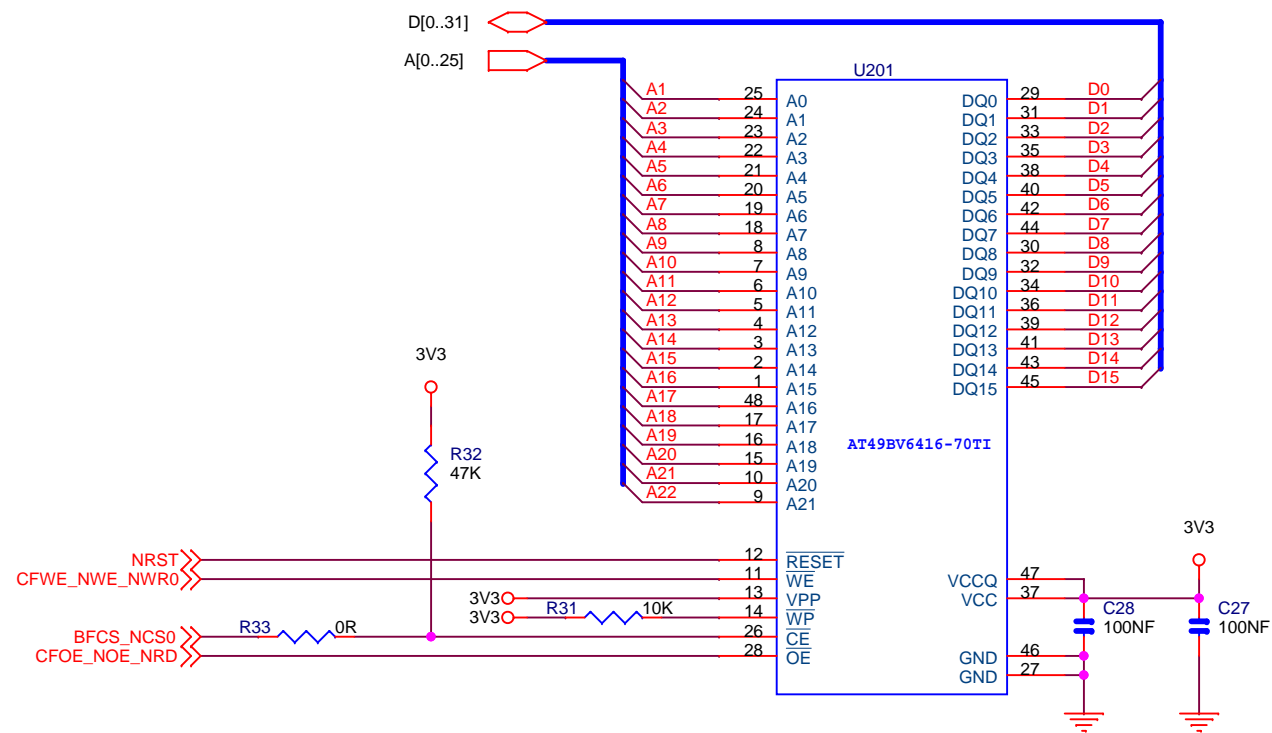
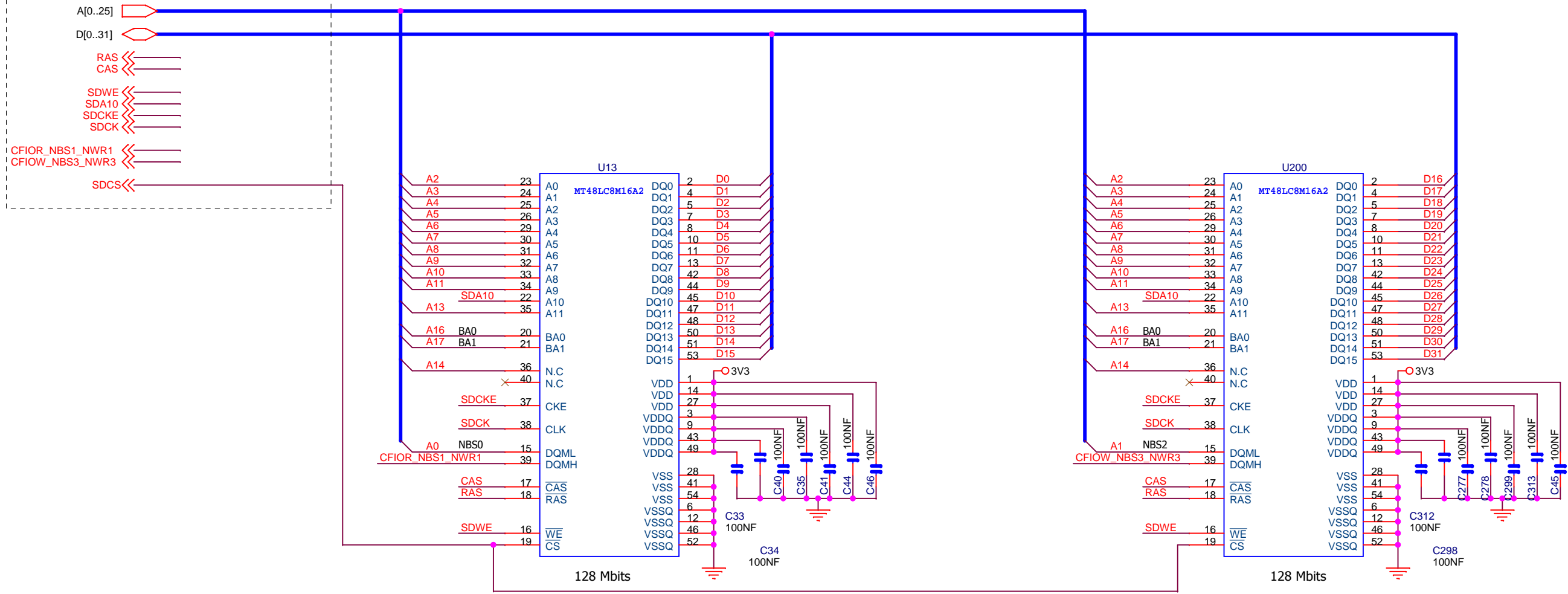

Monday, March 21, 2005

ATMEL ROUSSET					
AT91RM9200-EK		SCALE 1/1		REV. SHEET	
SDRAM & FLASH		63SC042261 A01		4/9	
A01	101-3-05-108	ELX	23/02/05	JPG	23/02/05
A	INIT EDIT	MDZ	04/01/05	JPG	06/01/05
REV	MODIF.	DES.	DATE	VER.	DATE

This agreement is our property. Reproduction and publication without our written authorization shall expose offender to legal proceedings.

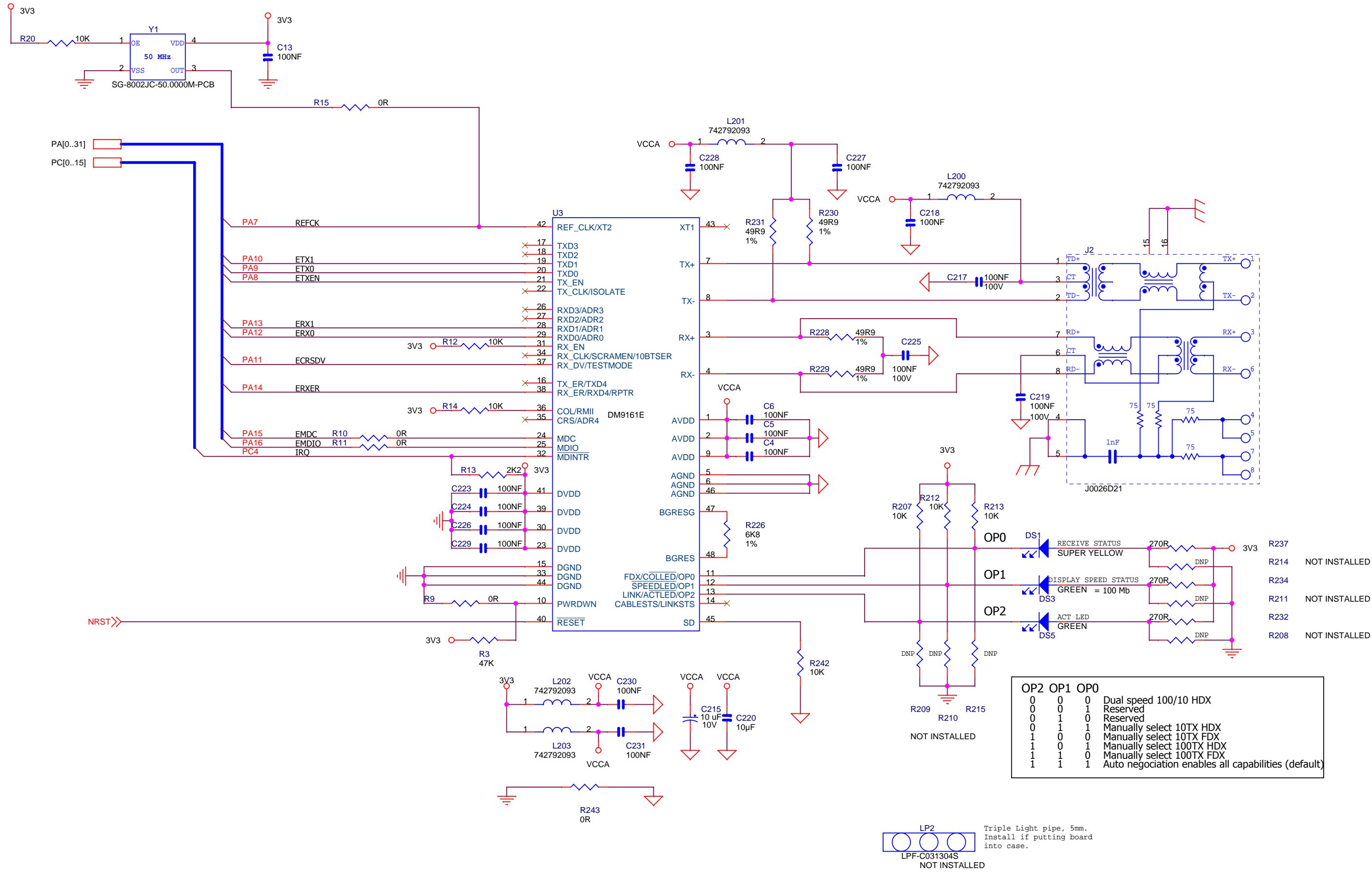

OP2	OP1	OP0	Description
0	0	0	Dual speed 100/10 HDX
0	0	1	Reserved
0	1	0	Reserved
0	1	1	Manually select 10TX HDX
1	0	0	Manually select 10TX FDX
1	0	1	Manually select 100TX HDX
1	1	0	Manually select 100TX FDX
1	1	1	Auto negotiation enables all capabilities (default)

LP2 Triple Light pipe, 5mm.
Install if putting board into case.
LPF-C031304S NOT INSTALLED

Monday, March 21, 2005

		AT91RM9200-EK ETHERNET			
REV	MODIF.	DES.	DATE	VER.	DATE
A01	101-3-05-106	ELX	23/02/05	JPG	23/02/05
A	INIT EDIT	MDZ	04/01/05	JPG	06/01/05
SCALE 1/1		63SC042261		REV. A01	SHEET 5/9

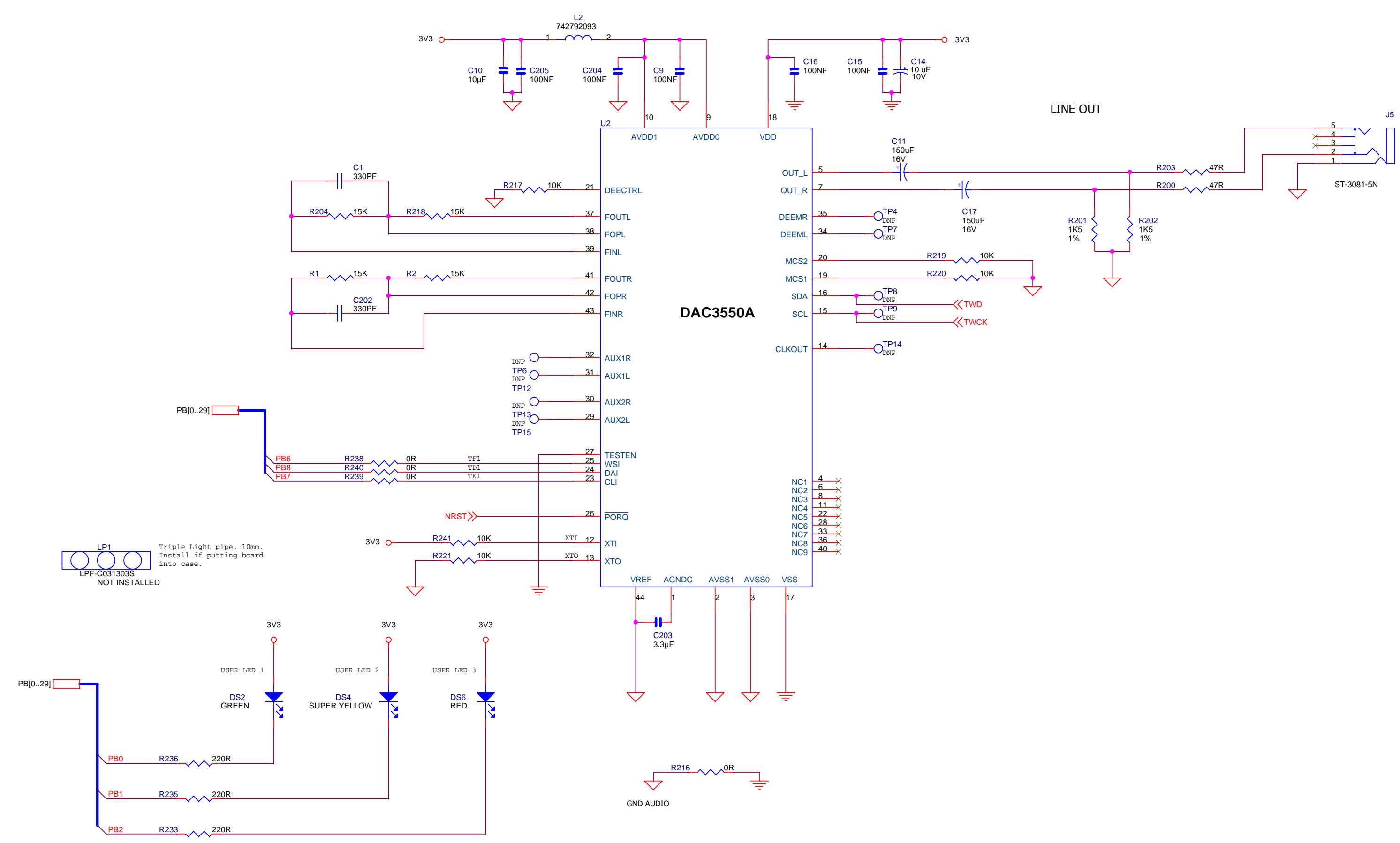

LP1 Triple Light pipe, 10mm.
Install if putting board into case.
LPF-C031303S
NOT INSTALLED

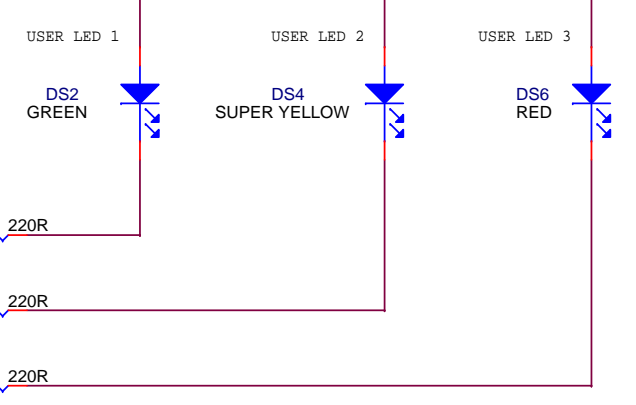

Monday, March 21, 2005

		<table border="1"> <tr> <td>A01</td> <td>101-3-05-106</td> <td>ELX</td> <td>23/02/05</td> <td>JPG</td> <td>23/02/05</td> </tr> <tr> <td>A</td> <td>INIT EDIT</td> <td>MDZ</td> <td>04/01/05</td> <td>JPG</td> <td>06/01/05</td> </tr> <tr> <td>REV</td> <td>MODIF.</td> <td>DES.</td> <td>DATE</td> <td>VER.</td> <td>DATE</td> </tr> </table>				A01	101-3-05-106	ELX	23/02/05	JPG	23/02/05	A	INIT EDIT	MDZ	04/01/05	JPG	06/01/05	REV	MODIF.	DES.	DATE	VER.	DATE
		A01	101-3-05-106	ELX	23/02/05	JPG	23/02/05																
A	INIT EDIT	MDZ	04/01/05	JPG	06/01/05																		
REV	MODIF.	DES.	DATE	VER.	DATE																		
AT91RM9200-EK I2S STEREO DAC		SCALE 1/1 	63SC042261A01		REV. SHEET 6/9																		

This agreement is our property. Reproduction and publication without our written authorization shall expose offender to legal proceedings.

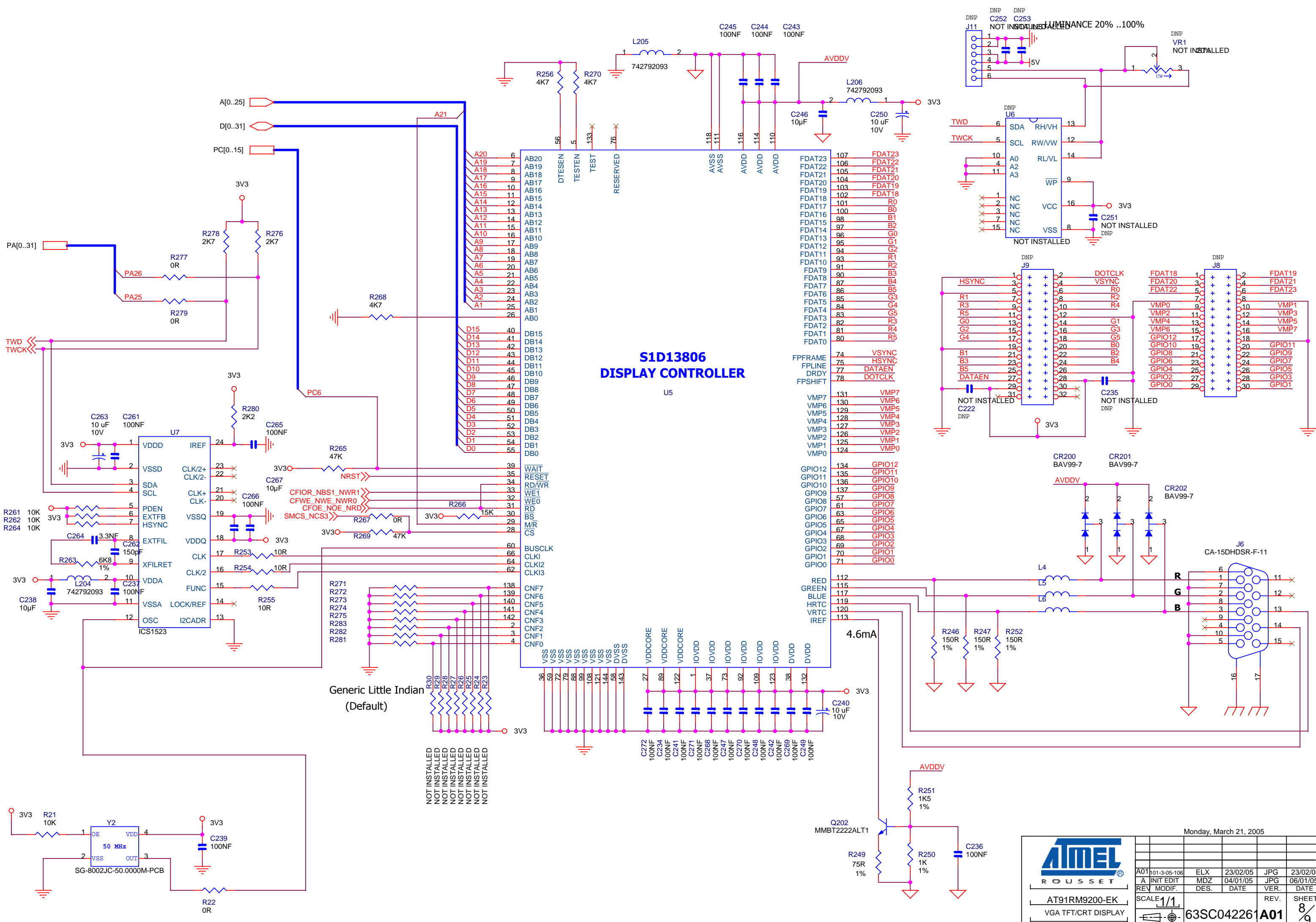

**S1D13806
DISPLAY CONTROLLER**

Monday, March 21, 2005

ATMEL ROUSSET					
A01	101-3-05-106	ELX	23/02/05	JPG	23/02/05
A	INIT EDIT	MDZ	04/01/05	JPG	06/01/05
REV	MODIF.	DES.	DATE	VER.	DATE
SCALE 1/1		63SC042261A01		REV.	SHEET 8/9

AT91RM9200-EK
VGA TFT/CRT DISPLAY

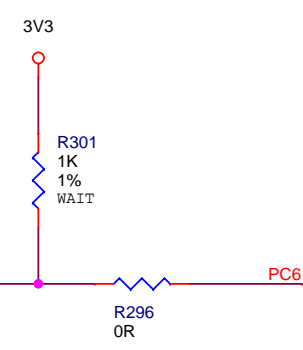
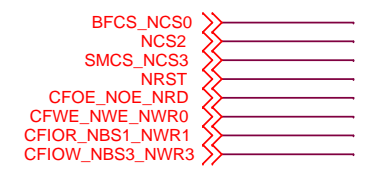
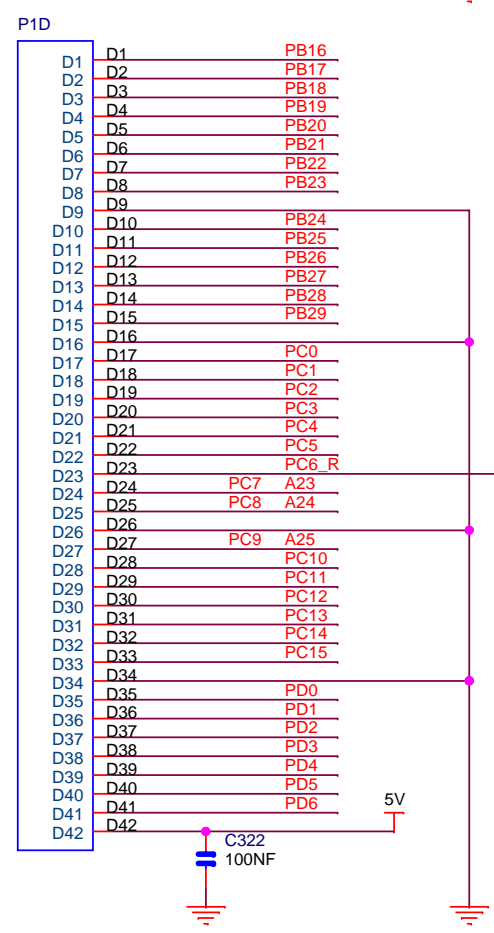
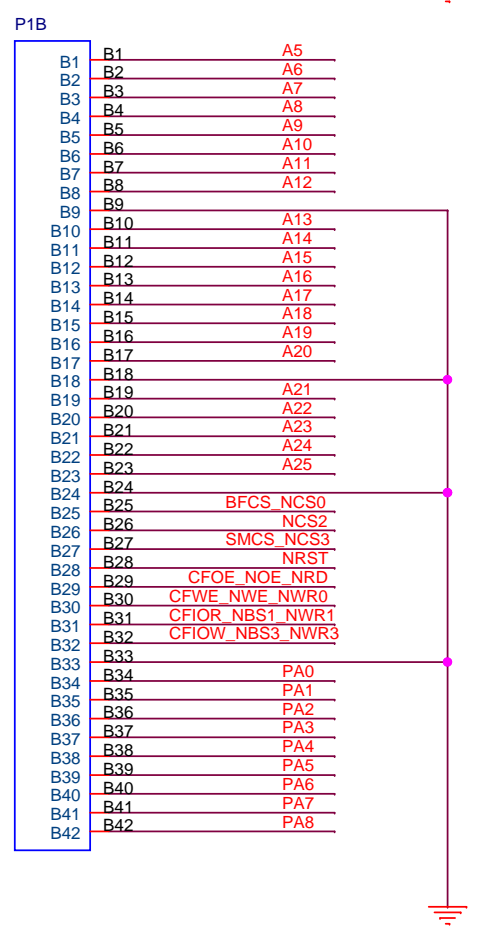
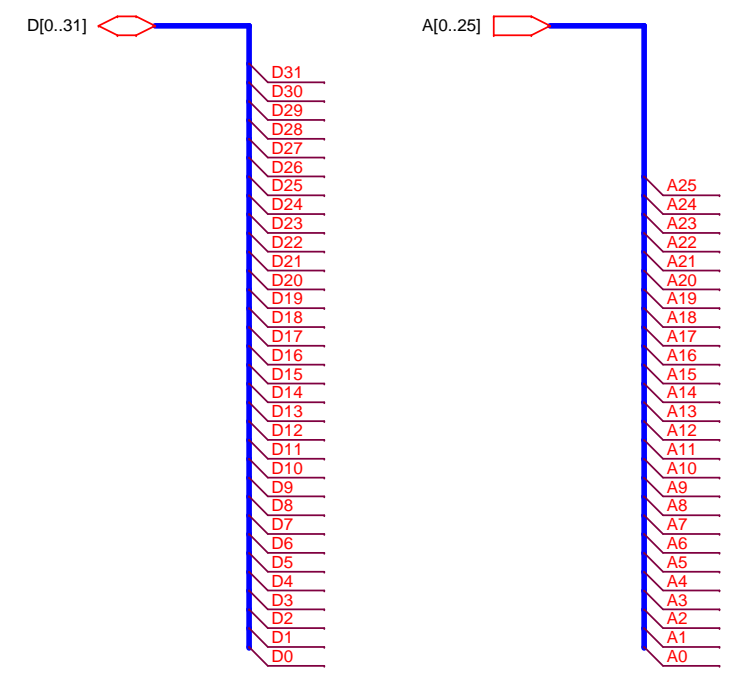
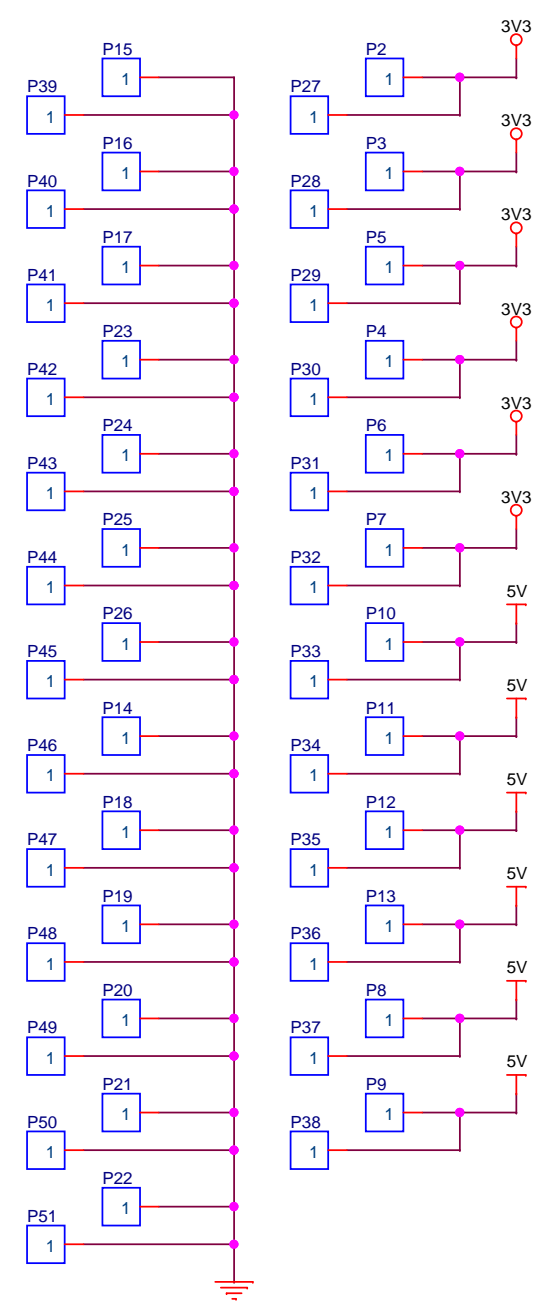
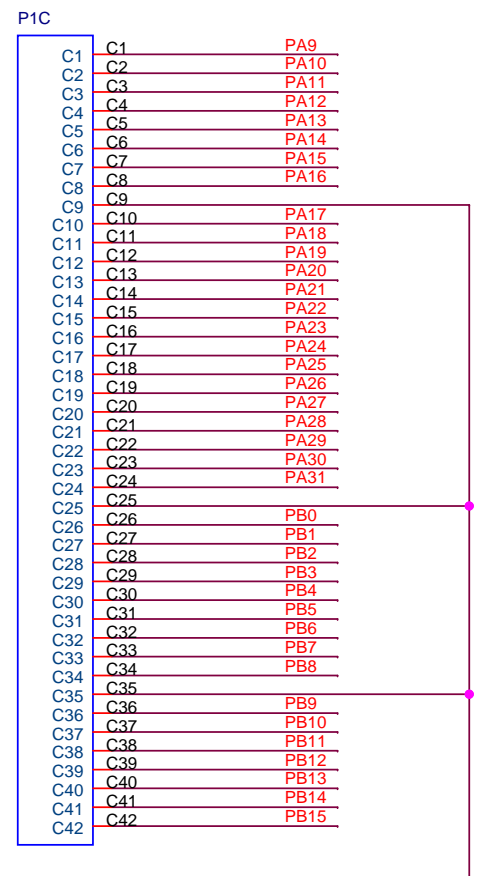
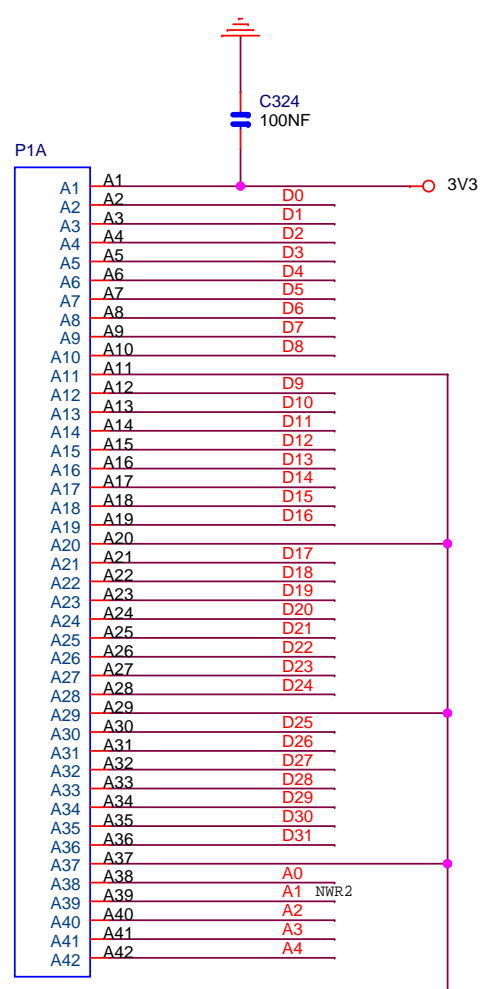
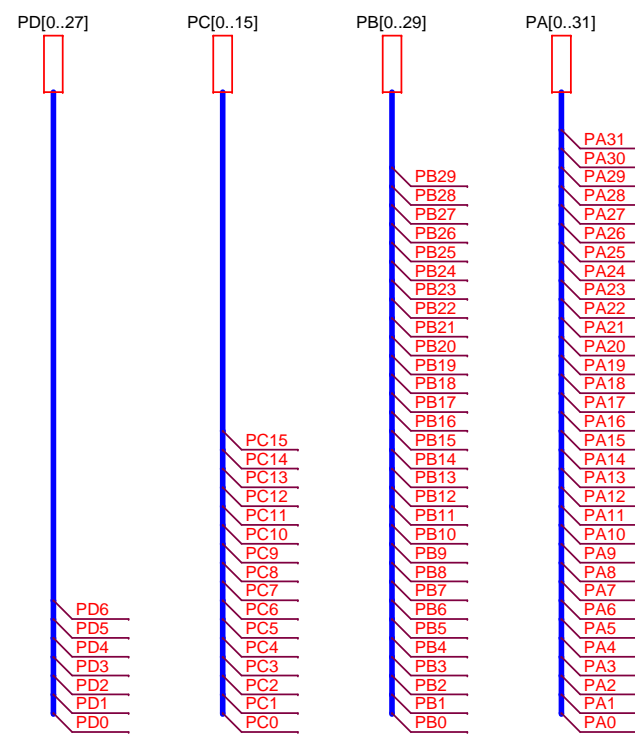

Monday, March 21, 2005

AT91RM9200-EK
EXPANSION CONNECTORS

A01	101-3-05-106	ELX	23/02/05	JPG	23/02/05
A	INIT EDIT	MDZ	04/01/05	JPG	06/01/05
REV	MODIF.	DES.	DATE	VER.	DATE
SCALE	1/1			REV.	SHEET
				63SC04226	A01
					9/9

This agreement is our property. Reproduction and publication without our written authorization shall expose offender to legal proceedings.



Revision History

Doc. Rev.	Date	Comments	Change Request Ref.
6103A	24-Sep-04	First issue.	
6103B	02-Mar-05 19-Jul-05	Section 1.2, "Deliverables" on page 2; List simplified Table 4-1, Boot information modified New schematics added in Section 5.	CSR 04-361, CSR 05-028, CSR 05-246



Atmel Corporation

2325 Orchard Parkway
San Jose, CA 95131, USA
Tel: 1(408) 441-0311
Fax: 1(408) 487-2600

Regional Headquarters

Europe

Atmel Sarl
Route des Arsenaux 41
Case Postale 80
CH-1705 Fribourg
Switzerland
Tel: (41) 26-426-5555
Fax: (41) 26-426-5500

Asia

Room 1219
Chinachem Golden Plaza
77 Mody Road Tsimshatsui
East Kowloon
Hong Kong
Tel: (852) 2721-9778
Fax: (852) 2722-1369

Japan

9F, Tonetsu Shinkawa Bldg.
1-24-8 Shinkawa
Chuo-ku, Tokyo 104-0033
Japan
Tel: (81) 3-3523-3551
Fax: (81) 3-3523-7581

Atmel Operations

Memory

2325 Orchard Parkway
San Jose, CA 95131, USA
Tel: 1(408) 441-0311
Fax: 1(408) 436-4314

Microcontrollers

2325 Orchard Parkway
San Jose, CA 95131, USA
Tel: 1(408) 441-0311
Fax: 1(408) 436-4314

La Chantrerie
BP 70602
44306 Nantes Cedex 3, France
Tel: (33) 2-40-18-18-18
Fax: (33) 2-40-18-19-60

ASIC/ASSP/Smart Cards

Zone Industrielle
13106 Rousset Cedex, France
Tel: (33) 4-42-53-60-00
Fax: (33) 4-42-53-60-01

1150 East Cheyenne Mtn. Blvd.
Colorado Springs, CO 80906, USA
Tel: 1(719) 576-3300
Fax: 1(719) 540-1759

Scottish Enterprise Technology Park
Maxwell Building
East Kilbride G75 0QR, Scotland
Tel: (44) 1355-803-000
Fax: (44) 1355-242-743

RF/Automotive

Theresienstrasse 2
Postfach 3535
74025 Heilbronn, Germany
Tel: (49) 71-31-67-0
Fax: (49) 71-31-67-2340

1150 East Cheyenne Mtn. Blvd.
Colorado Springs, CO 80906, USA
Tel: 1(719) 576-3300
Fax: 1(719) 540-1759

Biometrics/Imaging/Hi-Rel MPU/ High Speed Converters/RF Datacom

Avenue de Rochepleine
BP 123
38521 Saint-Egreve Cedex, France
Tel: (33) 4-76-58-30-00
Fax: (33) 4-76-58-34-80



Literature Requests

www.atmel.com/literature

Disclaimer: The information in this document is provided in connection with Atmel products. No license, express or implied, by estoppel or otherwise, to any intellectual property right is granted by this document or in connection with the sale of Atmel products. **EXCEPT AS SET FORTH IN ATMEL'S TERMS AND CONDITIONS OF SALE LOCATED ON ATMEL'S WEB SITE, ATMEL ASSUMES NO LIABILITY WHATSOEVER AND DISCLAIMS ANY EXPRESS, IMPLIED OR STATUTORY WARRANTY RELATING TO ITS PRODUCTS INCLUDING, BUT NOT LIMITED TO, THE IMPLIED WARRANTY OF MERCHANTABILITY, FITNESS FOR A PARTICULAR PURPOSE, OR NON-INFRINGEMENT. IN NO EVENT SHALL ATMEL BE LIABLE FOR ANY DIRECT, INDIRECT, CONSEQUENTIAL, PUNITIVE, SPECIAL OR INCIDENTAL DAMAGES (INCLUDING, WITHOUT LIMITATION, DAMAGES FOR LOSS OF PROFITS, BUSINESS INTERRUPTION, OR LOSS OF INFORMATION) ARISING OUT OF THE USE OR INABILITY TO USE THIS DOCUMENT, EVEN IF ATMEL HAS BEEN ADVISED OF THE POSSIBILITY OF SUCH DAMAGES.** Atmel makes no representations or warranties with respect to the accuracy or completeness of the contents of this document and reserves the right to make changes to specifications and product descriptions at any time without notice. Atmel does not make any commitment to update the information contained herein. Unless specifically provided otherwise, Atmel products are not suitable for, and shall not be used in, automotive applications. Atmel's products are not intended, authorized, or warranted for use as components in applications intended to support or sustain life.

© Atmel Corporation 2005. All rights reserved. Atmel®, logo and combinations thereof, Everywhere You Are®, DataFlash® and others are registered trademarks or trademarks of Atmel Corporation or its subsidiaries. ARM®, Thumb® and others are the registered trademarks of ARM Ltd. Other terms and product names may be the trademarks of others.



Printed on recycled paper.

6103B-ATARM-30-Sep-05